

# What is GIS?

- A special kind of Information System
- Special information about *what is where* on the Earth's surface
- is a system designed **to capture, store, manipulate, analyze, manage, and present all types of spatial or geographical data.**

# History of GIS: the 1960's

- First attempts at computer-based map overlay
- Leader: Canada GIS (CGIS)
  - Goal: to develop land management plans for large areas of rural Canada
  - Factors: forest & mineral resources, wildlife habitats, water resources
  - Hindered by limitations of computers similar to our modern hand calculator!

# History of GIS: the 1960's

- the **Canadian Geographic Information System (CGIS)** was the first operational GIS
- developed in the early 1960's (era of large mainframe computer systems)
- the system was designed to inventory land use and assist in the management of natural resources in Canada
- Roger Tomlinson is considered the "Father of GIS" for his role in the development of the CGIS

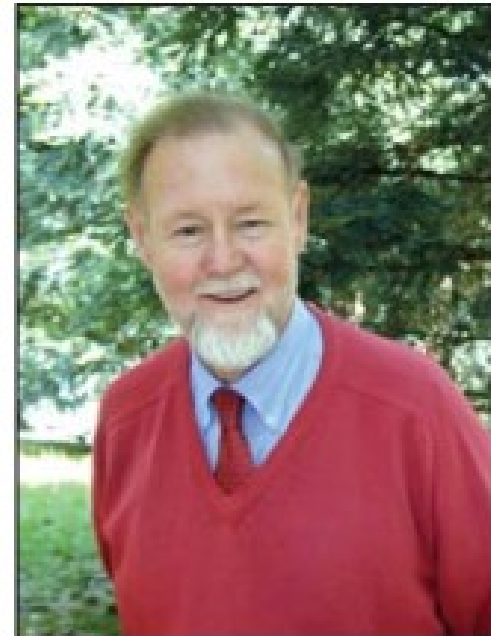

# 1960's: Academia

- Harvard Laboratories - "SYMAP"
- First real demonstration of computer's ability to make maps
- Aim: produce thematic maps of statistical data depicted in census tracts quickly and cheaply

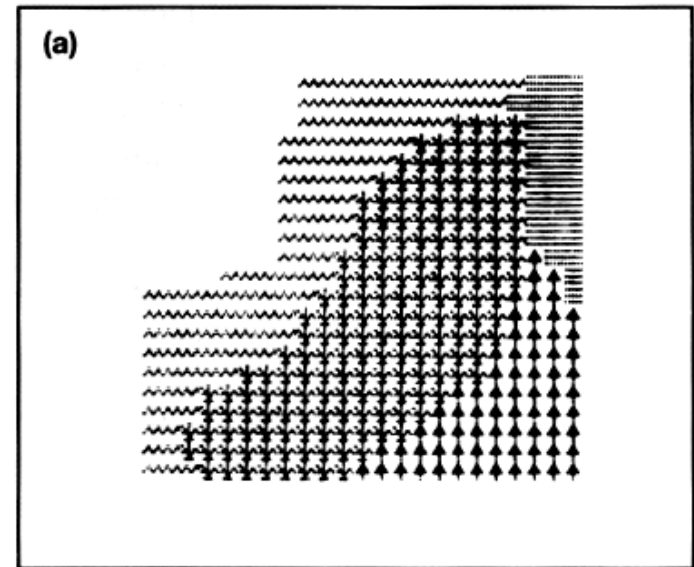

~~~~~	Gravel
***	Clay loam
***	Silt loam
====	Loam

# US Government: The Census Bureau

- Goal: Create a digital version of various types of maps
- Functions needed:
  - Comprehensive set of street maps for whole country
  - Analyze and report data at different levels: *Addresses > Blocks > Census tracts*
- 1970 census included a digital map

# Industry

- Environmental Systems Research Institute (ESRI)
  - Environmental consulting firm founded in 1969
  - Digital mapping products needed were unavailable, so...
- Intergraph
  - Founded by former IBM Engineer in 1969 as M&S Computing
  - Later renamed to *Intergraph Corporation* in 1980
  - Initially: Computer-Assisted Drafting (CAD) and Computer-Assisted Manufacturing (CAM)

# GIS Software

Store | Contact Us | Careers

**ESRI** GIS and Mapping Software

Home Products Services Industries Training Support Events News About ESRI

Better Decisions Through Modeling and Mapping Our World  
**Geographic Information Systems**

ArcGIS  
the Complete GIS

- Desktop GIS
- Server GIS
- Mobile GIS
- ArcGIS Online
- Data

About this map | Map Books

- we use GIS software products developed by Esri
  - original name: Environmental Systems Research Institute
  - then became known as ESRI – now Esri
- Esri is a privately held software company
  - owned by Jack and Laura Dangermond
- headquarters located in Redlands, California
  - regional offices throughout the U.S. and the world



## Esri Software History

- prior to the summer of 2001 ESRI had two main software products

### 1) ARC/INFO

- a professional GIS originally developed in the 1970's
- command-line software package (used DOS) – difficult to use

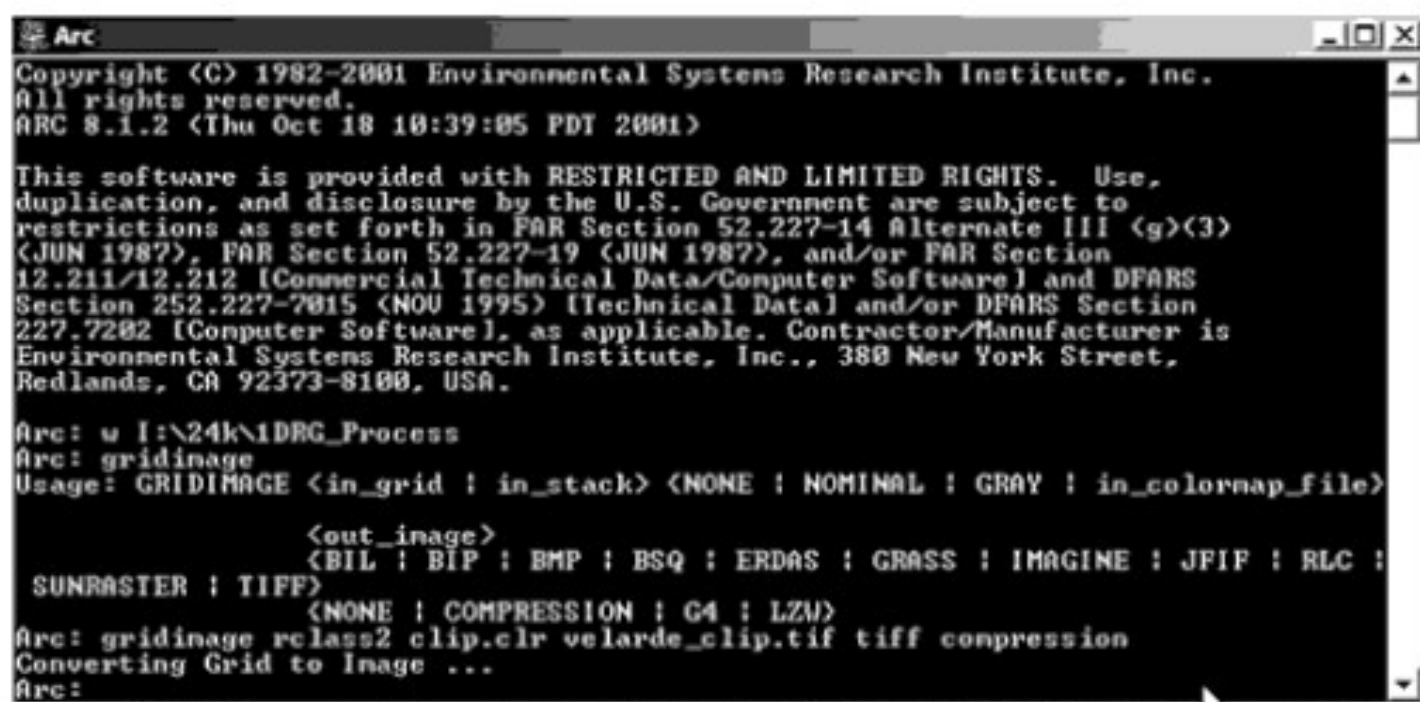

```
Arc
Copyright (C) 1982-2001 Environmental Systems Research Institute, Inc.
All rights reserved.
ARC 8.1.2 (Thu Oct 18 10:39:05 PDT 2001)

This software is provided with RESTRICTED AND LIMITED RIGHTS. Use,
duplication, and disclosure by the U.S. Government are subject to
restrictions as set forth in FAR Section 52.227-14 Alternate III (g)(3)
(JUN 1987), FAR Section 52.227-19 (JUN 1987), and/or FAR Section
12.211/12.212 [Commercial Technical Data/Computer Software] and DFARS
Section 252.227-7015 (NOV 1995) [Technical Data] and/or DFARS Section
227.7202 [Computer Software], as applicable. Contractor/Manufacturer is
Environmental Systems Research Institute, Inc., 380 New York Street,
Redlands, CA 92373-8100, USA.

Arc: w I:\24k\1DRG_Process
Arc: gridimage
Usage: GRIDIMAGE <in_grid ; in_stack> <NONE ; NOMINAL ; GRAY ; in_colormap_file>
        <out_image>
        <BIL ; BIP ; BMP ; BSQ ; ERDAS ; GRASS ; IMAGINE ; JPIP ; RLC ;
SUNRASTER ; TIFF>
        <NONE ; COMPRESSION ; C4 ; LZJ>
Arc: gridimage reclass2 clip.clr velarde_clip.tif tiff compression
Converting Grid to Image ...
Arc:
```



## 2) ArcView

- a desktop GIS using Windows - developed in the 1990's
- original version was developed as a viewer for data analyzed in ARC/INFO
- throughout the 1990's ArcView evolved into a powerful desktop GIS

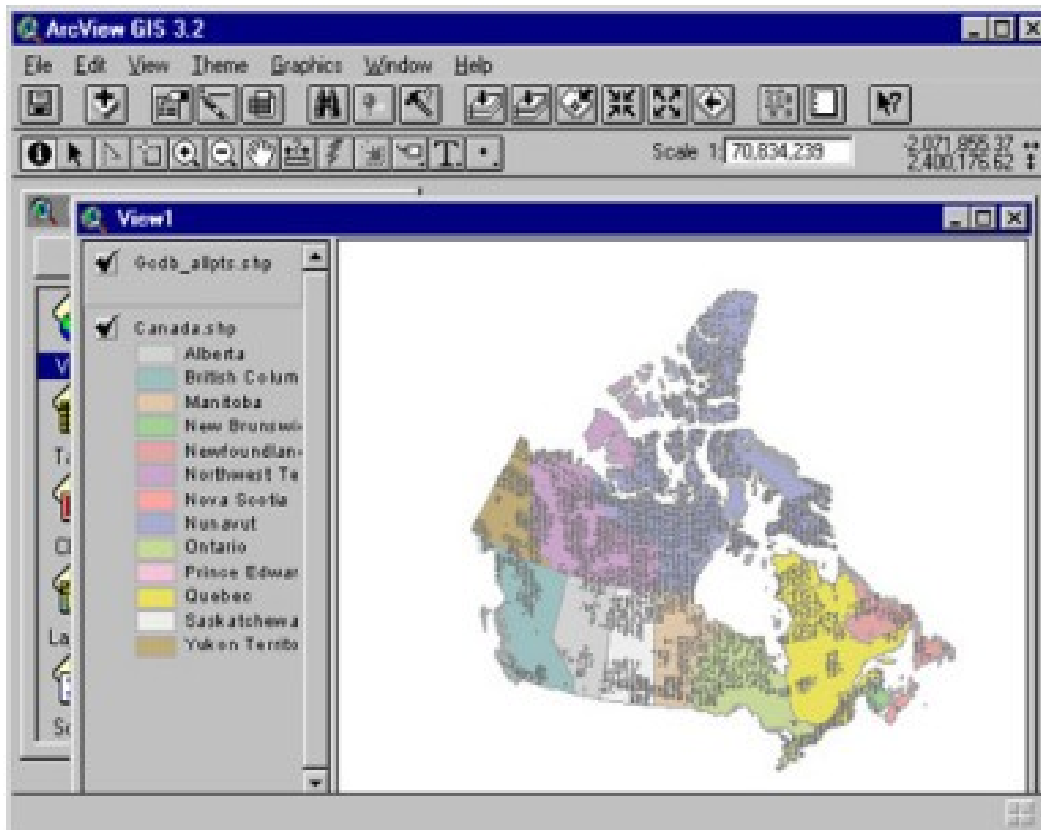

- easy to use
- graphic user interface

## Esri Software History



### Summer 2001

- ESRI introduced **ArcGIS** (a suite of GIS software programs)
- main advantage is one user interface with all functionality
- ArcGIS 10 consists of two main application programs:
  - ArcMap and ArcCatalog
- can be licensed at three levels with increasing functionality:  
Basic, Standard, and Advanced
- there are also many extensions available to the core ArcGIS software including:
  - Spatial Analyst
  - 3D Analyst
  - Network Analyst
  - Business Analyst, etc

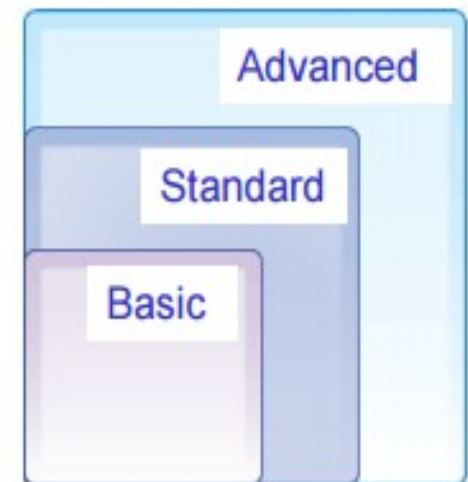

# Esri Software History

Summary: 1970s to 2000 Two Separate Programs



ARC/INFO  
- professional GIS

ArcView  
- desktop GIS



summer 2001

ArcGIS  
- suite of software  
- two main application programs inside ArcGIS



ArcMap  
- mapping and analysis

ArcCatalog  
- file management



versions of ArcGIS with increasing functionality

Advanced	X	X
Standard	X	X
Basic	X	X

# Application area of GIS



A tax assessor's office produces land use maps for appraisers and planners.

An engineering department monitors the condition of roads and bridges and produces planning maps for natural disasters.



A water department finds the valves to isolate a ruptured water main.



A transit department produces maps of bicycle paths for commuters.



A police department studies crime patterns to intelligently deploy its personnel and to monitor the effectiveness of neighborhood watch programs.

A wastewater department prioritizes areas for repairs after an earthquake.



# Application area of GIS

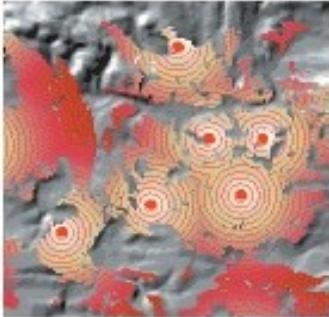

A telecommunication company studies the terrain to find locations for new cell phone antennae.

A hydrologist monitors water quality to protect public health.

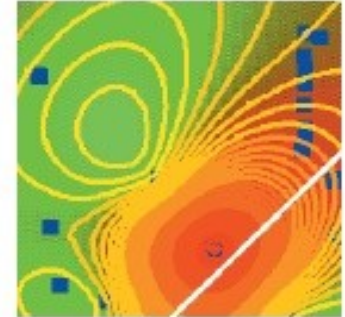

A pipeline company finds the least-cost path for a new pipeline.

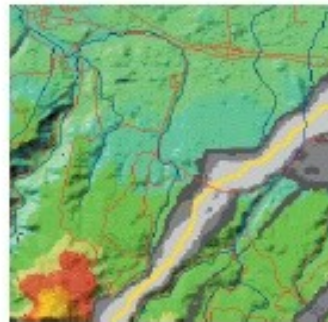

A biologist studies the impact of construction plans on a watershed.



An electric utility models its circuits to minimize power loss and to plan the placement of new devices.

A meteorologist issues warnings for counties in the path of a severe storm.



# Application area of GIS

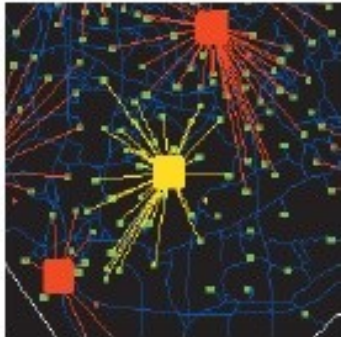

A business evaluates locations for new retail outlets by considering nearby concentrations of customers.

A police dispatcher finds the fastest route to an emergency.



An emergency management agency plans relief facilities by modeling demand and accessibility.

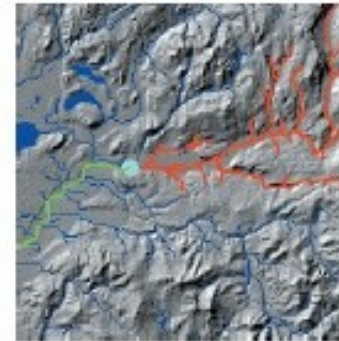

A water resource manager traces upstream to find the possible sources of a contaminant.



A fire fighting team predicts the spread of a forest fire using terrain and weather data.

# Benefit of GIS

- Cost Savings from Greater Efficiency
- Improved Communication
- Better Decision Making
- Better Record Keeping
- Managing Geographically

<http://www.esri.com/what-is-gis>

# Components of GIS

- Computer Hardware
- Computer Software
  - Tools for the input and manipulation of geographic information
  - A database management system (DBMS)
  - Tools that support geographic query, analysis, and visualization
  - A graphical user interface (GUI) for easy access to tools

## Spatial Data from REAL WORLD

- One of the most important but often expensive component
- Trained Personnel
- Methods



# Components of GIS

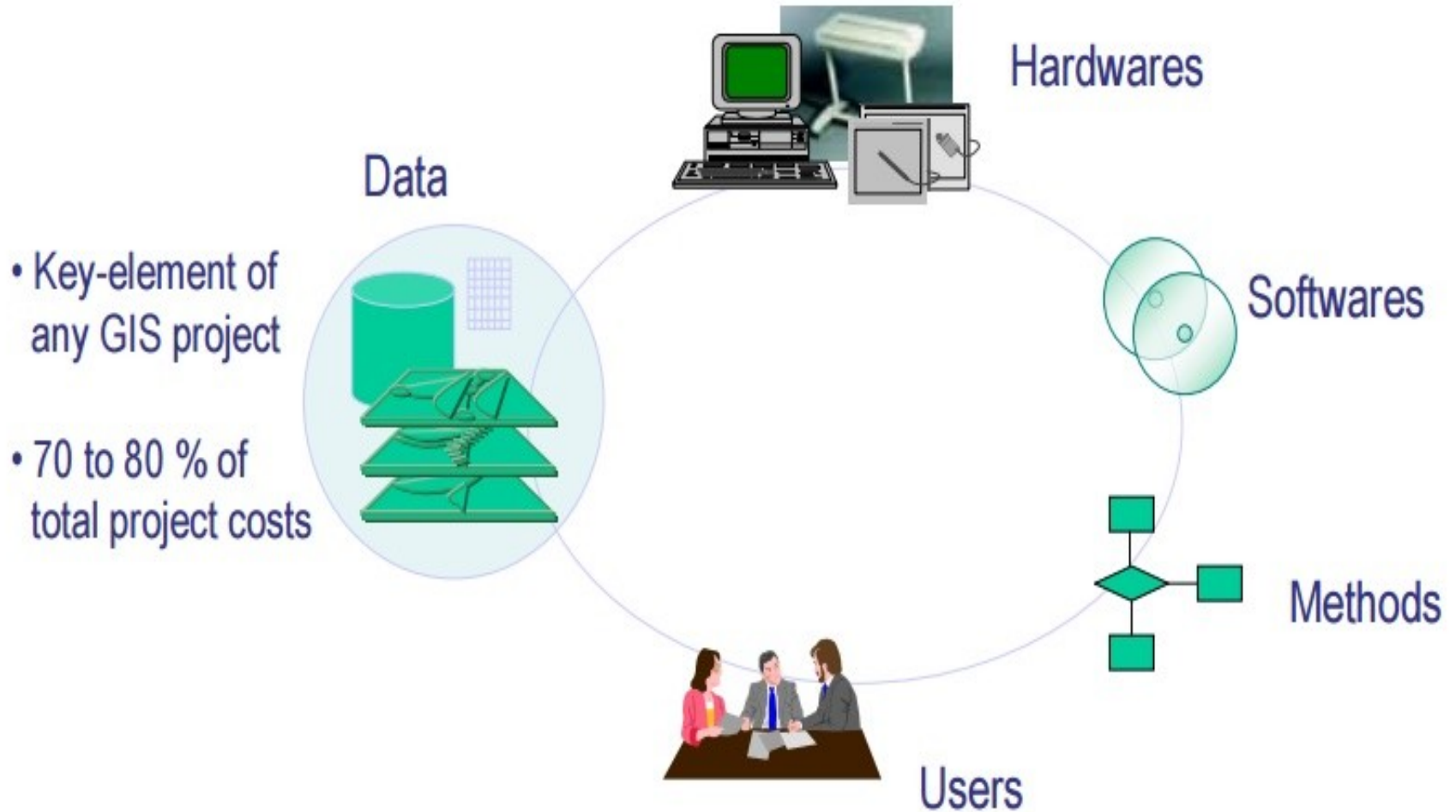

# Functional Components of GIS

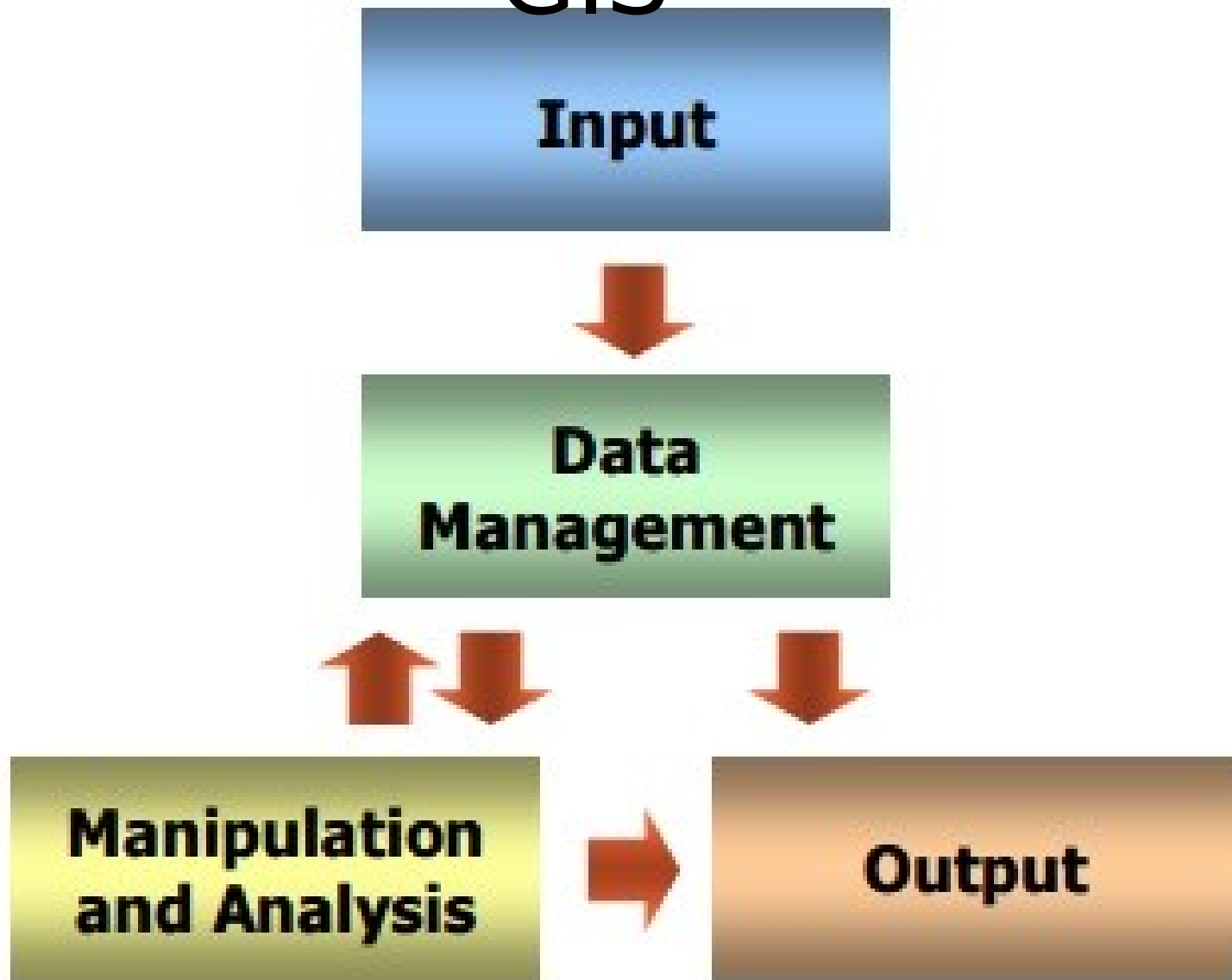

# Functions of GIS

GIS Functions:

To manage and analyze spatial data, a GIS has 6 majors functions.

GIS software must provide the user with the ability to:

- Capture,
- Store,
- Edit or Manipulate,
- Query,
- Analyze,
- and Display

... spatial data

Capture

Store

Edit

Query

Analyze

Display

# Major GIS-Only Journals

- Cartography and Geographic Information Science
- Geographic Information Systems
- GeoInformatica
- International Journal of Geographical Information Science
- Journal of Geographical Systems
- Visual Geosciences
- Transactions in GIS
- Journal of Geographic Information and Decision Analysis

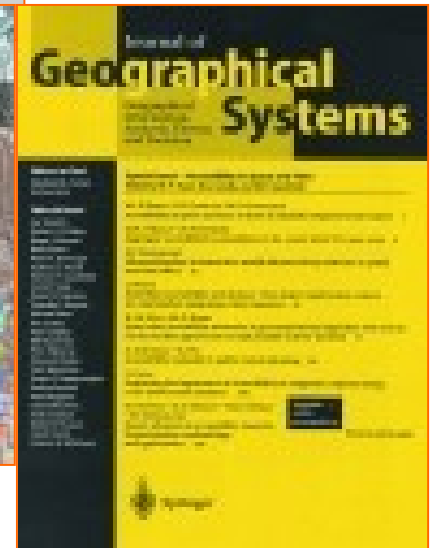
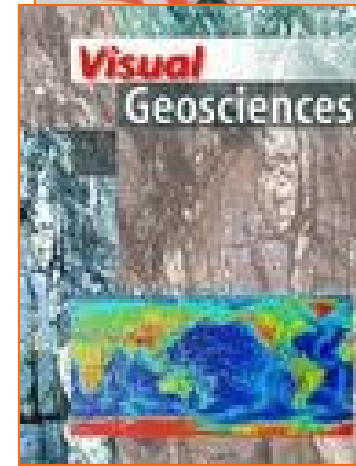
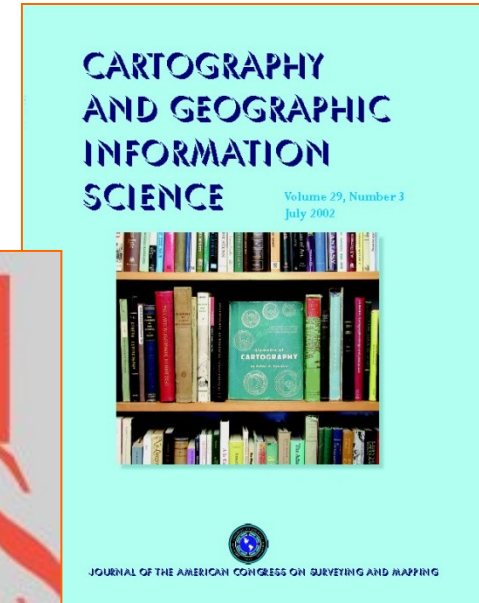
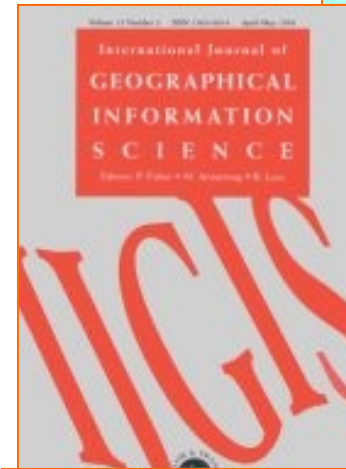

# Specialty Journals

- GIS Law
- GrassClippings
- GIS Asia/Pacific
- GIS World  
Report/CANADA
- GIS Europe
- Mapping Awareness

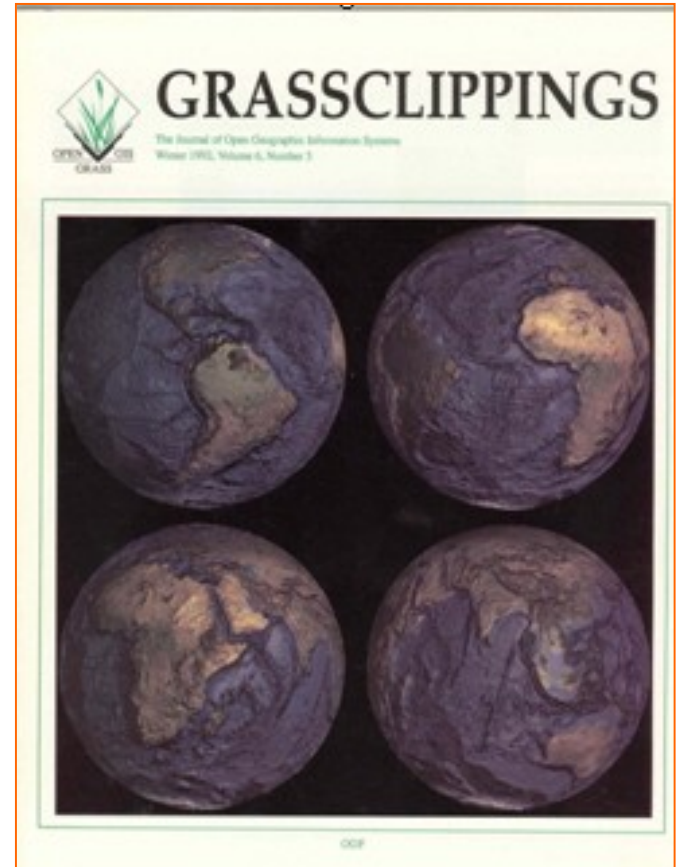

# Regular GIS Papers

- Annals of the Association of American Geographers
- Cartographica
- Cartography and GIS
- Computers, Environment, and Urban Systems
- Computers and Geosciences
- IEEE Transactions on Computer Graphics and Applications
- Photogrammetric Engineering and Remote Sensing

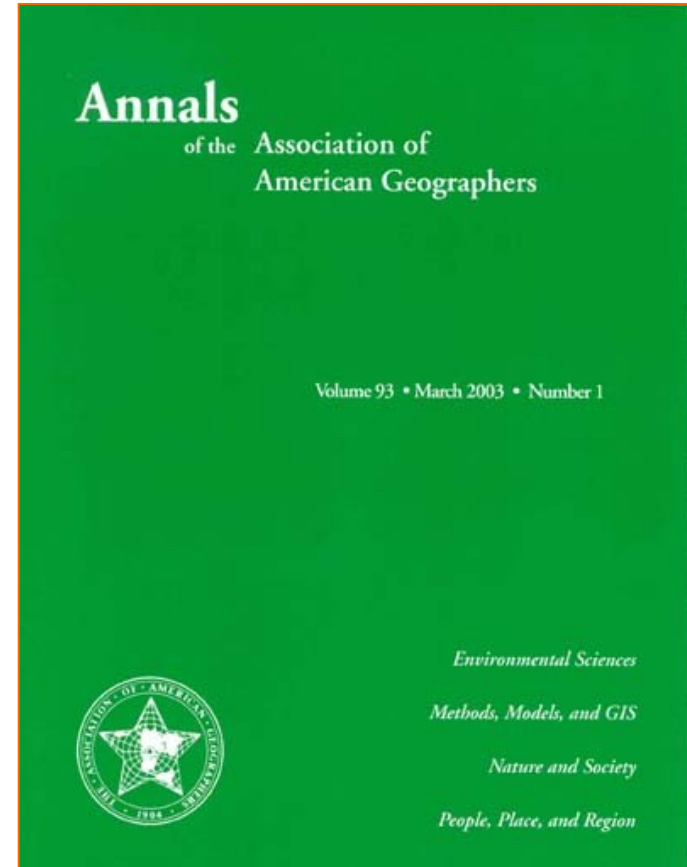

# Occasional GIS papers

- Cartographic Perspectives
- Journal of Cartography
- Geocarto International
- IEEE Geosciences
- International Journal of Remote Sensing
- Landscape Ecology
- Remote Sensing Review
- Mapping Science and Remote Sensing
- Infoworld

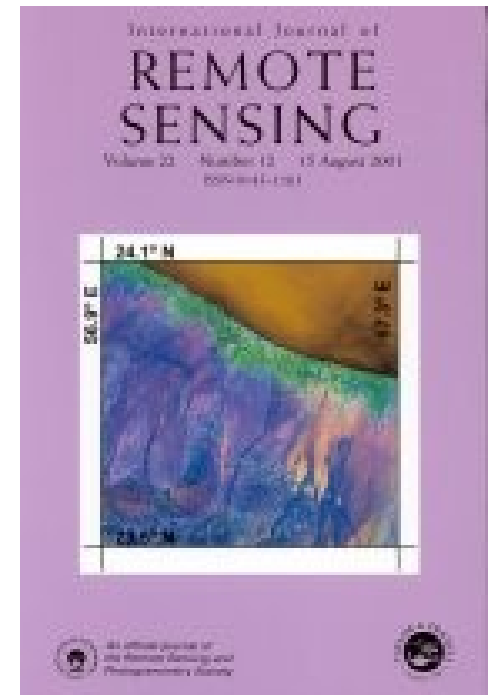

# Popular Distribution Magazines some with free subscriptions

- Geospatial Solutions
- ArcNews
- ArcUser
- Geoplace (online)
- GPS World

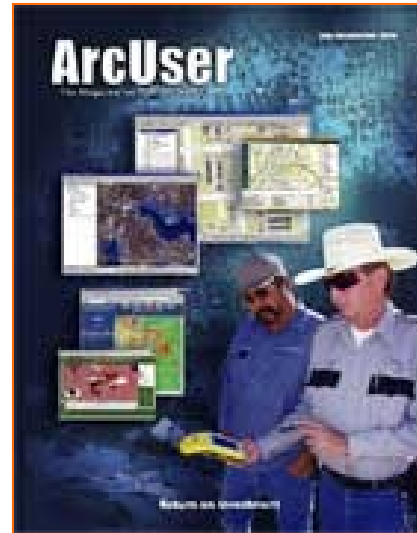

## Geospatial solutions

# MAPS ON YOUR MIND?

▶ HOME
▶ ABOUT US
▶ CURRENT ISSUE
▶ RECENT ISSUES
▶ SUBSCRIBE/RENEW
▶ SEARCH



# Chapter II

# Methods of Data Capture

- Field Data Collection
  - (Global Positioning Systems technology)
  - COGO, or Coordinate Geometry technology that gives you the flexibility of using geometry factors to delimitate features, such as curves, intersections, centerlines, etc.
- Satellite Data
  - LANDSAT
  - SPOT
- Map Scanning
- Digitization
- Photogrammetric Compilation (Aerial Photographs)
- Tabular Data Entry
- Translation of Existing Digital Data

# Spatial Data

⌘ How should discrete objects be coded?

- Vector Data Model
- Raster Data Model

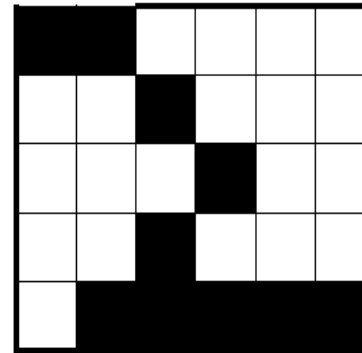

Raster Model

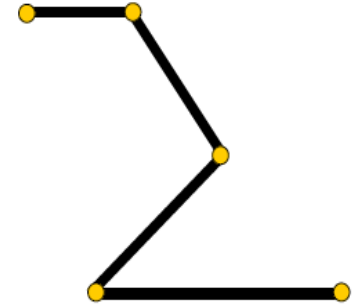

Vector Model

## RASTER PRESENTATION

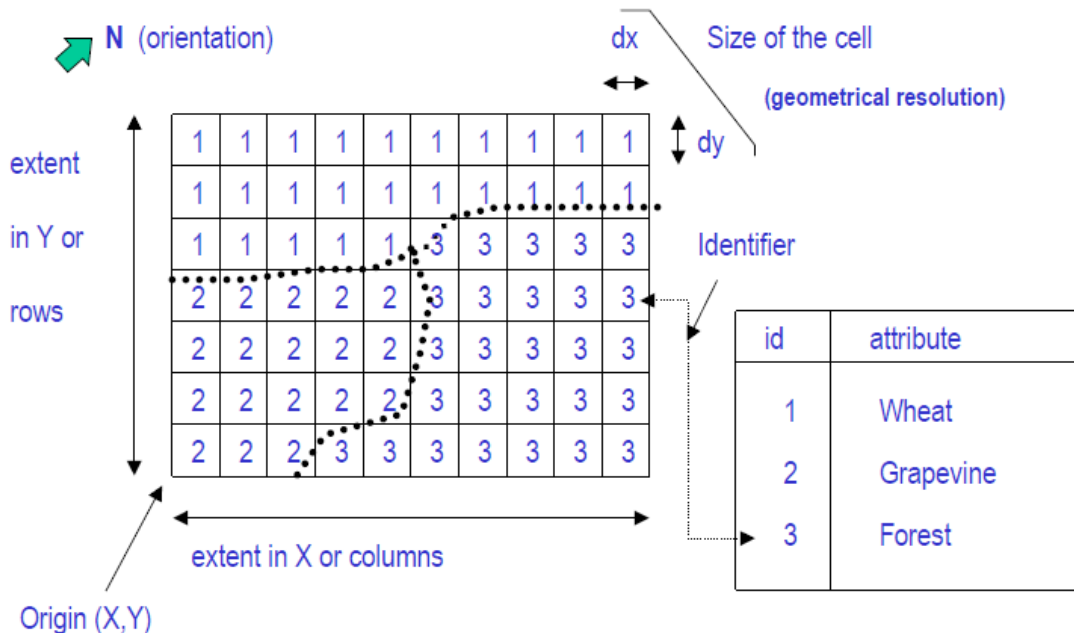

# Spatial Data Model

## Simple Vector Data Structure

Vector Line

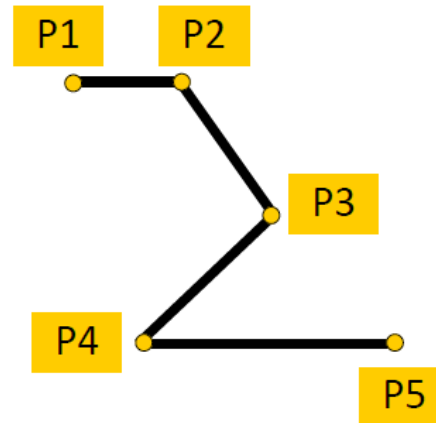

Table of Points

ID	X	Y
P1	503200	3200522
P2	503250	3200522
P3	503300	3200460
P4	503245	3200410
P5	503350	3200410

(in UTM coordinates)

## Simple Raster Data Structure:

Raster Line

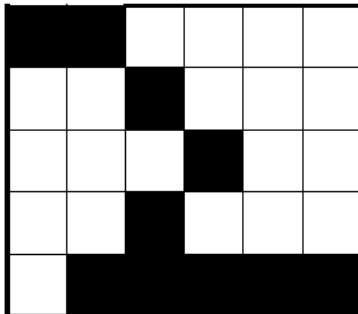

Equivalent Binary Flat File

1	1	0	0	0	0
0	0	1	0	0	0
0	0	0	1	0	0
0	0	1	0	0	0
0	1	1	1	1	1

# Vector Data Model

Logical Models

Vector Model

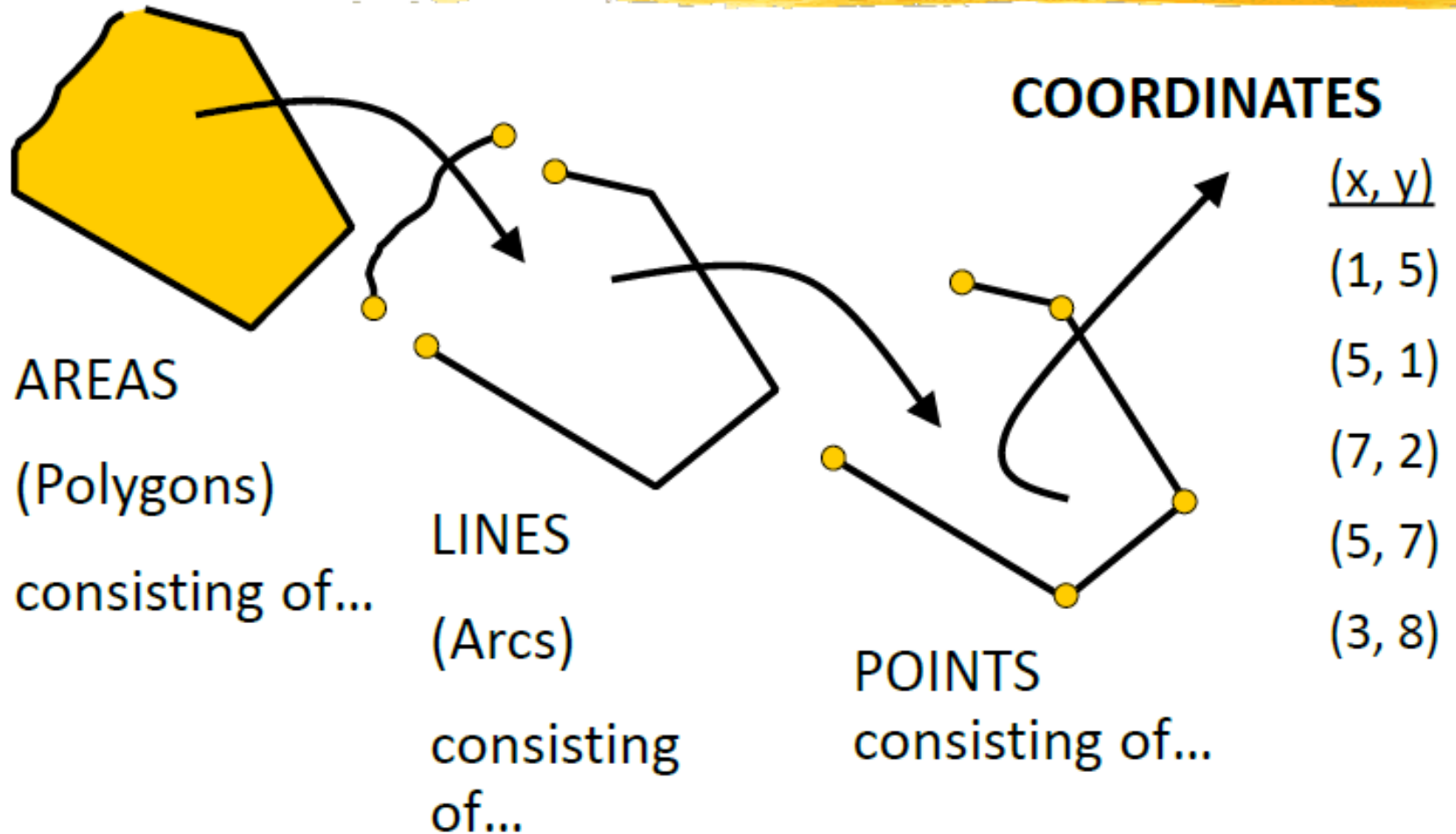

# Vector Data “Graphical” Vector Model

- ⌘ Lines have arbitrary beginning and end, like spaghetti on a plate



- ⌘ Common lines between adjacent polygons duplicated

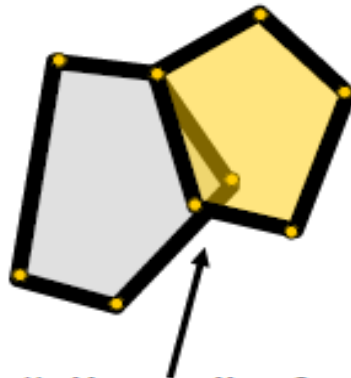

- ⊠ Can lead to “slivers” of unassigned area = “sliver polygons”

# Vector Data

## Topological Vector Model

---

- ⌘ Store pts. as x,y geographic coordinates
- ⌘ Store lines as paths of connected pts.
- ⌘ Store polygons as closed paths

Also explicitly store ....

- ⌘ Where lines start and end (connectivity)
- ⌘ Which polygons are to the right and left side of a common line (adjacency)

# Vector Data

## Lines: Graphic vs. Topologic

### ⌘ Graphic (Spaghetti)

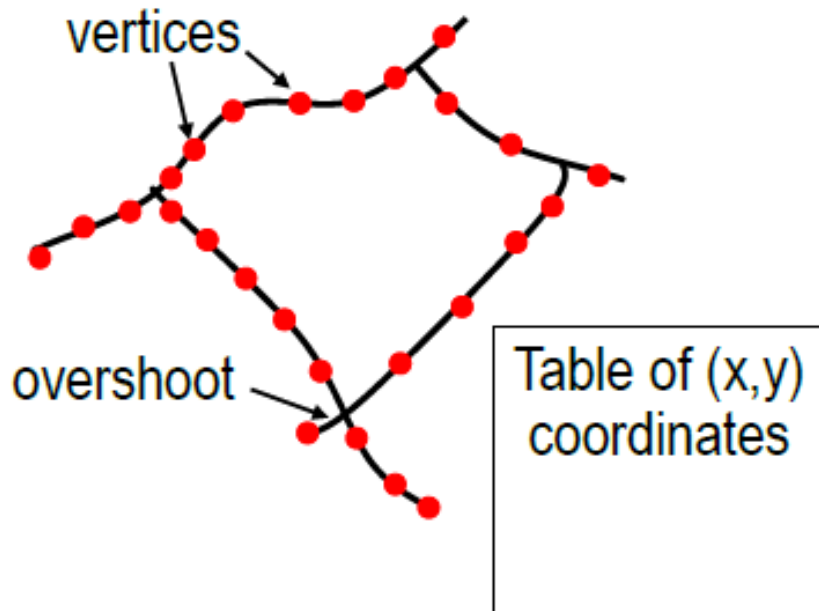

### ⌘ Topologic (with meatballs)

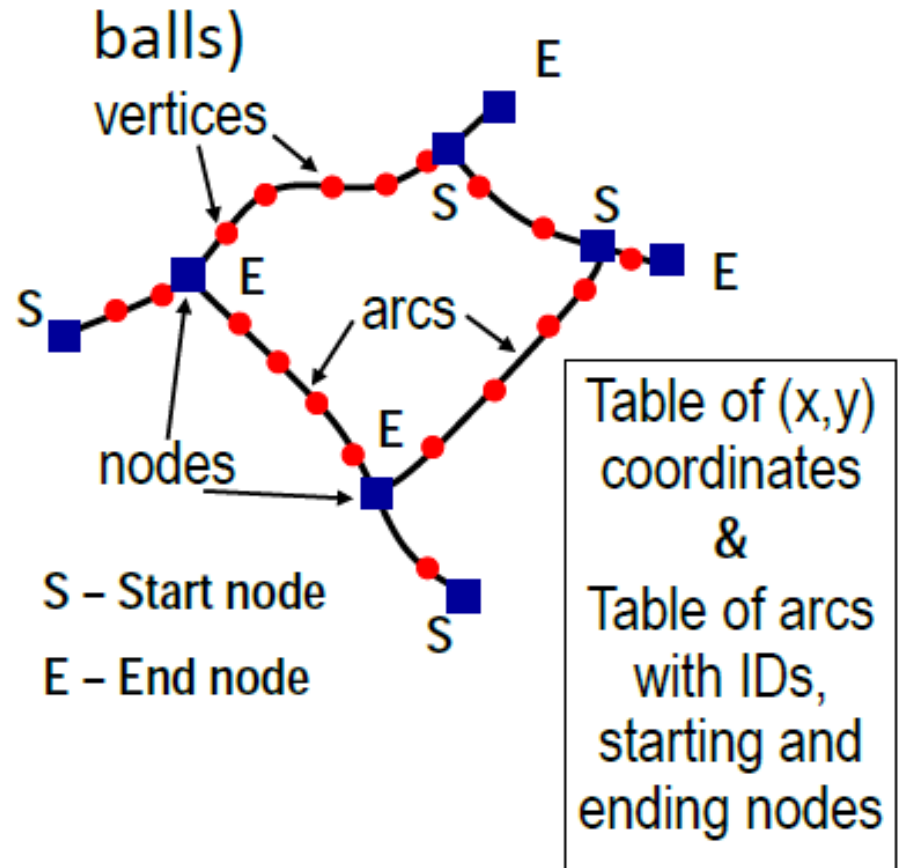



# Vector Data Model

## Lines: Arc-Node Topology

Vertex Table

ID	x	y
1	0	0
.	.	.
.	.	.
19	3	5

Node Table

ID	x	y
1	0	0
.	.	.
.	.	.
8	3	5

numbered vertices

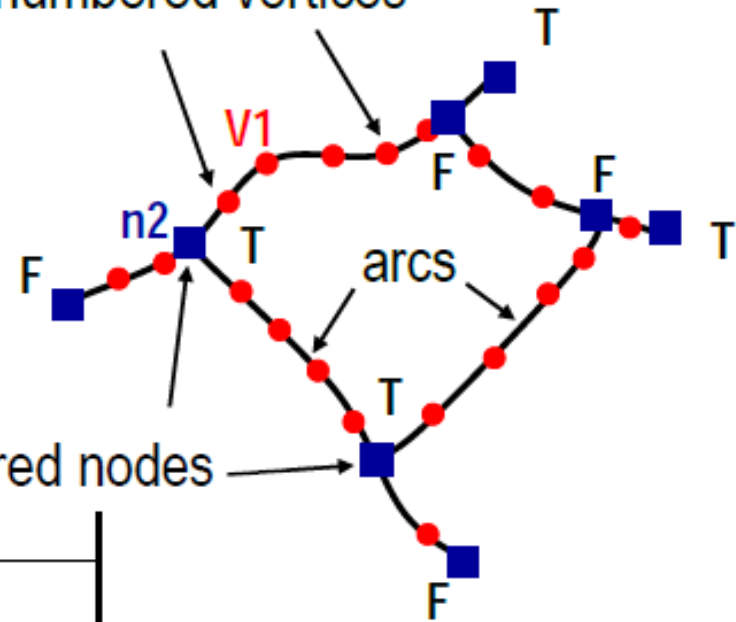

numbered nodes

Arc Table

ID	FID	F Node	T Node	Vertices
1	100	1	2	1, 2
2	102	3	2	3, 4, 5, 6, 7
3	103	3	4	null

F = "Start" node (F: "From" node)

T = "End" node or (T: "To" node)

# Vector Data Model

## Polygons: Polygon-Arc Topology

Arc Table

<u>Arc ID</u>	<u>L. Poly</u>	<u>R. Poly</u>	<u>F. Node</u>	<u>T. Node</u>
A1	World	P1	N1	N2
A2	P1	P2	N2	N1
A3	P2	World	N2	N1

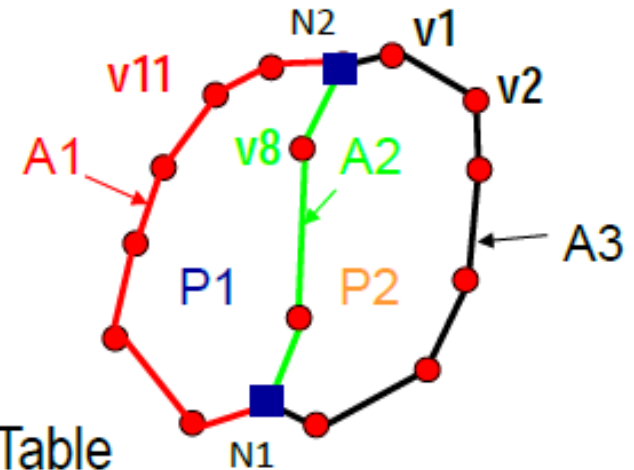

Polygon Table

<u>Poly ID</u>	<u>FID</u>	<u>Arcs.</u>
P1	100	A1, A2
P2	102	A2, A3

Arc Coordinates Table

<u>Arc</u>	<u>Start</u>	<u>Vertices</u>	<u>End</u>
A1	N1	v7, ..., v11, ...	N2
A2	N2	..., v8	N1
A3	N2	v1, v2, ..., v6	N1

# Vector Data Model

## Triangulated Irregular Network - TIN

- ✂ Topological 3-D model for representing continuous surfaces using a tessellation of triangles

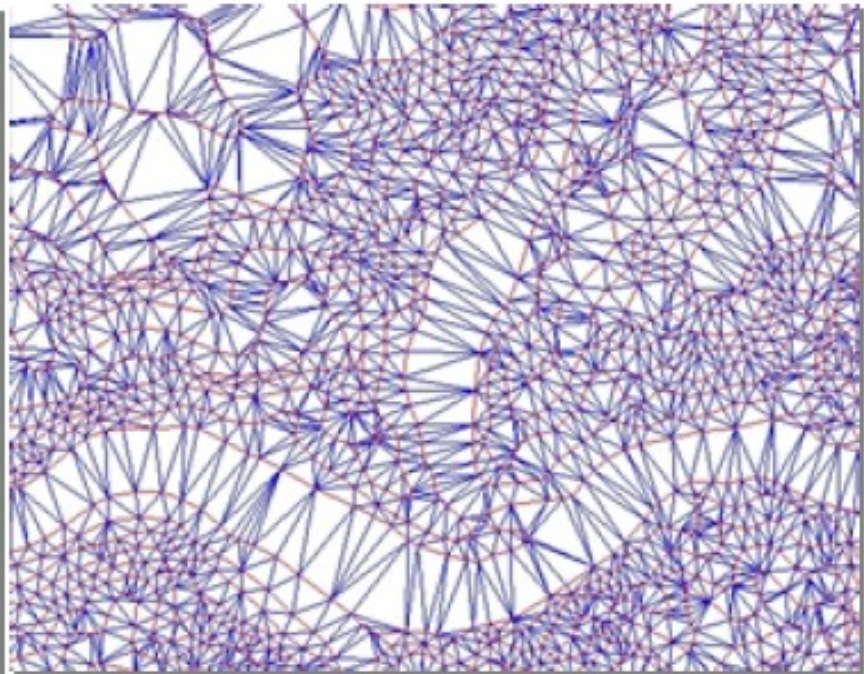
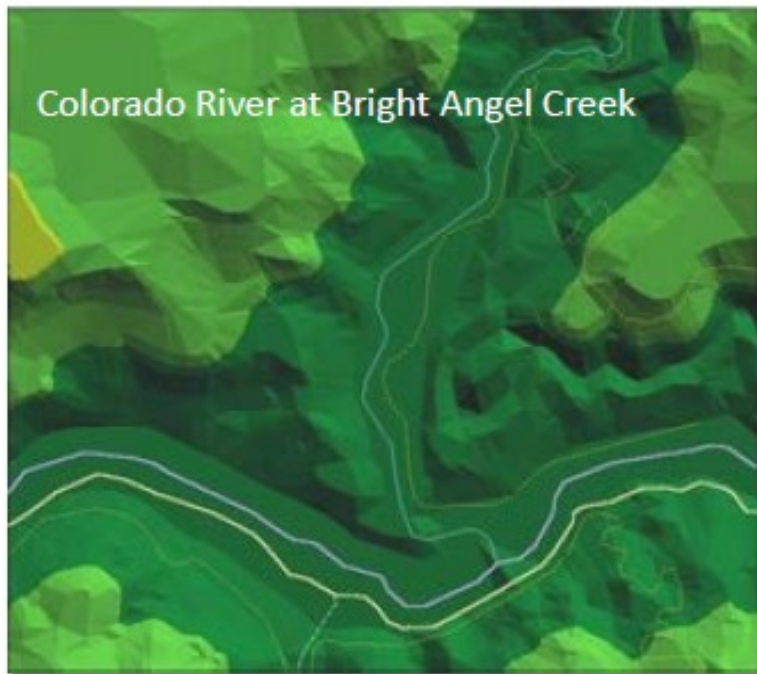

# Vector Data Model

## Triangular Irregular Network

- ⌘ Network of interlocking triangles from irregularly spaced points with  $x$ ,  $y$  and  $z$  values
- ⌘ Density of triangles varies with density of data points (e.g. spacing of contours) - c.f. raster with uniform data density
- ⌘ Triangle sides are constructed by connecting adjacent points so that the minimum angle of each triangle is maximized
- ⌘ Can render faces, calculate slope, aspect, surface shade, hidden-line removal, etc.

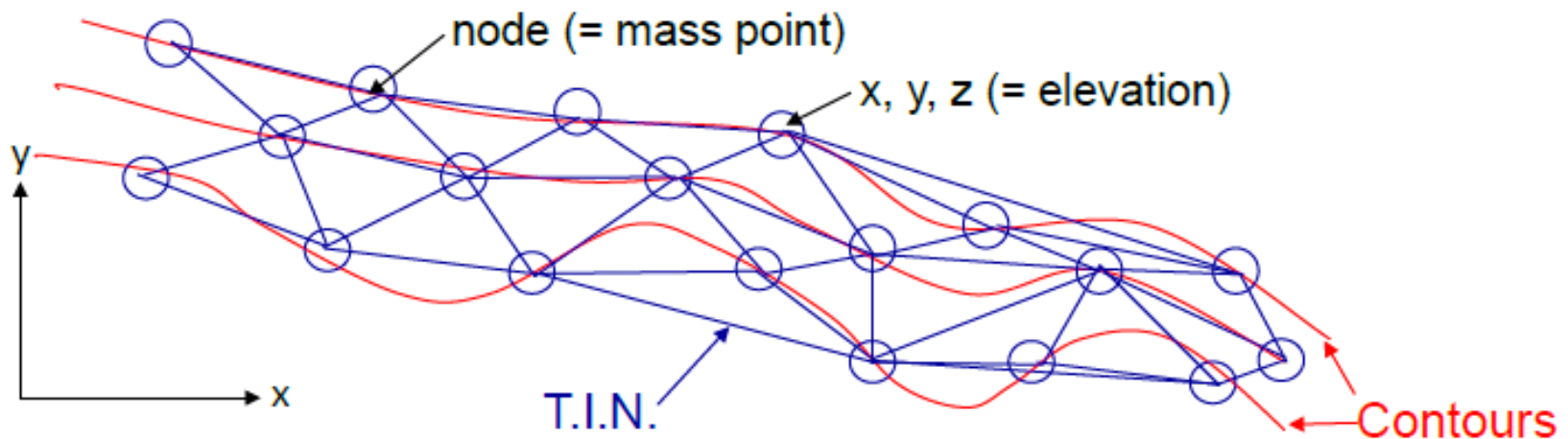

# Vector Data TIN Model

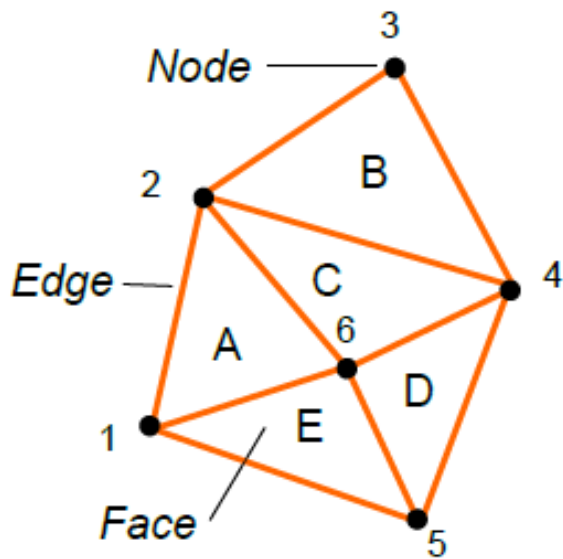

Node Table

Node	x	y	z
1	3	5	5
2	5	9	12
3	11	12	16
4	15	5	3
5	13	3	44
6	10	7	50

Tin Topology Table

Triangle	Node list	Neighbors
A	1, 2, 6	-, C, E
B	2, 3, 4	-, -, C
C	2, 4, 6	B, D, A
D	4, 5, 6	E, C, -
E	5, 1, 6	A, C, D



Node Elevations

# Spatial Data Model

## VECTOR/RASTER CONVERSIONS

### FROM VECTOR TO RASTER: RASTERIZATION

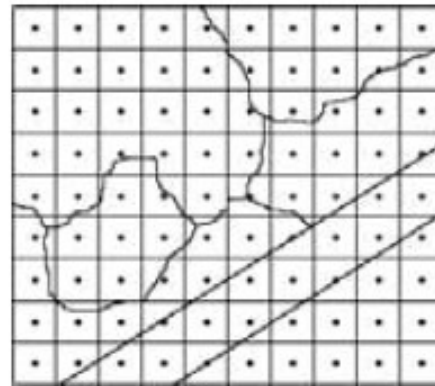
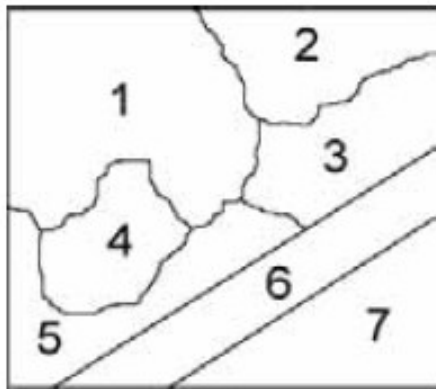

1	1	1	1	1	2	2	2	2	2
1	1	1	1	1	2	2	2	2	3
1	1	1	1	1	1	2	3	3	3
1	1	1	1	1	1	3	3	3	3
1	1	4	4	1	3	3	3	6	6
5	4	4	4	5	5	5	6	6	7
5	4	4	5	5	6	6	6	7	7
5	5	5	6	6	6	7	7	7	7
5	5	6	6	7	7	7	7	7	7

### FROM RASTER TO VECTOR: VECTORIZATION

1	1	1	1	1	2	2	2	2	2
1	1	1	1	1	2	2	2	2	3
1	1	1	1	1	1	2	3	3	3
1	1	1	1	1	1	3	3	3	3
1	1	4	4	1	3	3	3	6	6
5	4	4	4	5	5	5	6	6	7
5	4	4	5	5	6	6	6	7	7
5	5	5	6	6	6	7	7	7	7
5	5	6	6	7	7	7	7	7	7



1	1	1	1	1	2	2	2	2	2
1	1	1	1	1	2	2	2	2	3
1	1	1	1	1	1	2	3	3	3
1	1	1	1	1	1	3	3	3	3
1	1	4	4	1	3	3	3	6	6
5	4	4	4	5	5	5	6	6	7
5	4	4	5	5	6	6	6	7	7
5	5	5	6	6	6	7	7	7	7
5	5	6	6	7	7	7	7	7	7

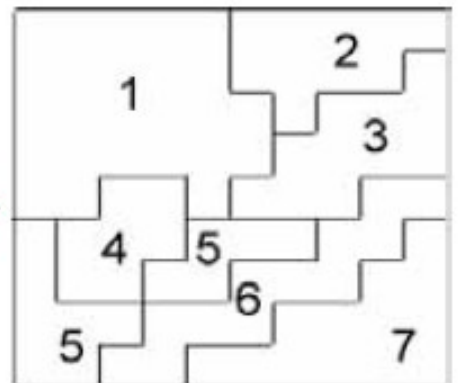

# Spatial Data Model

## RASTER REPRESENTATION: IMAGE DATA



Map (scanned)



Orthophotography

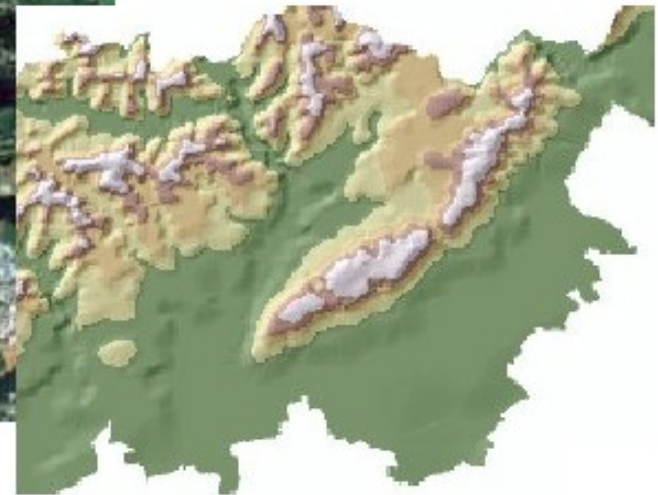

Digital Elevation Model

# Digitizing is:



- ⌘ Conversion of spatial data to digital form
  - ☑ Lines, points or polygons are traced to record coordinates of their locations
- ⌘ Term conventionally used to denote the process of creating VECTOR data
  - ☑ Scanning produces raster data (“bit maps”)
  - ☑ But software exists to convert raster to vector so can digitize (“vectorize”) scanned images



# Digitizing is accomplished via:

## ⌘ Digitizing table or tablet

- ☒ “heads-down” digitizing

- ☒ Large table once available in Rm. 6.202

## ⌘ A mouse, on screen

- ☒ “heads-up” digitizing

- ☒ Aerial photos, other raster or vector sources as base to digitize from

## ⌘ Software that converts raster to vector

- ☒ Vectorization – batch or interactive modes, e.g. ArcScan extension

# Digitizing table

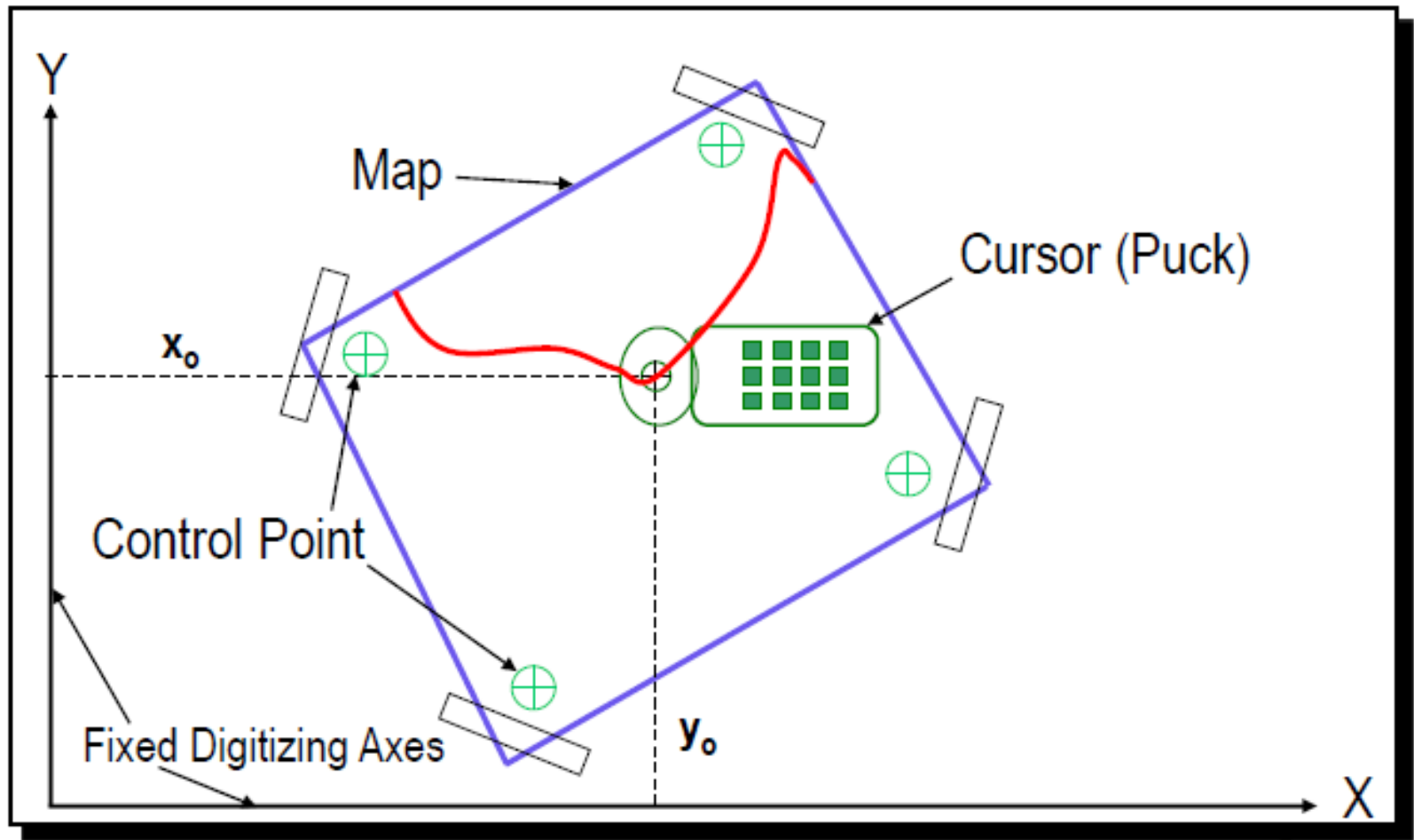

# Digitizing with a tablet involves:

- ⌘ Digitize 3 reference points – define position of map w.r.t. digitizing table
- ⌘ Establishing 4 or more control points - distinctive features at known locations that can be used to register the map to ground coordinates (e.g. UTM, lat./lon.)
- ⌘ Separating features as point, line or polygon and tracing them to separate files (themes)
- ⌘ Heads-up digitizing starts with georeferencing

# Heads-up digitizing



- ⌘ Decide whether new file will have planar enforcement
- ⌘ Create new point, line or polygon feature class(es) in ArcCatalog
- ⌘ Edit feature class(es) to add features and attributes
- ⌘ Stop editing
- ⌘ Save edits as part of new feature class

# GIS Analysis Model

Graphical modeling framework tied to actual GIS functions  
Functions, Data, Numerical Models, Tools, etc.

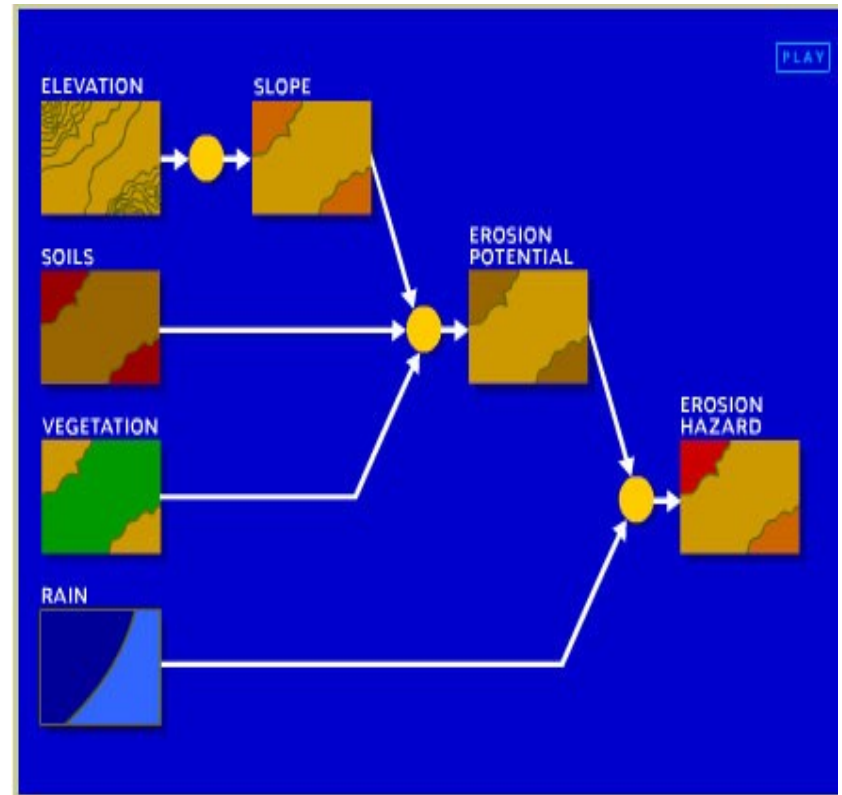
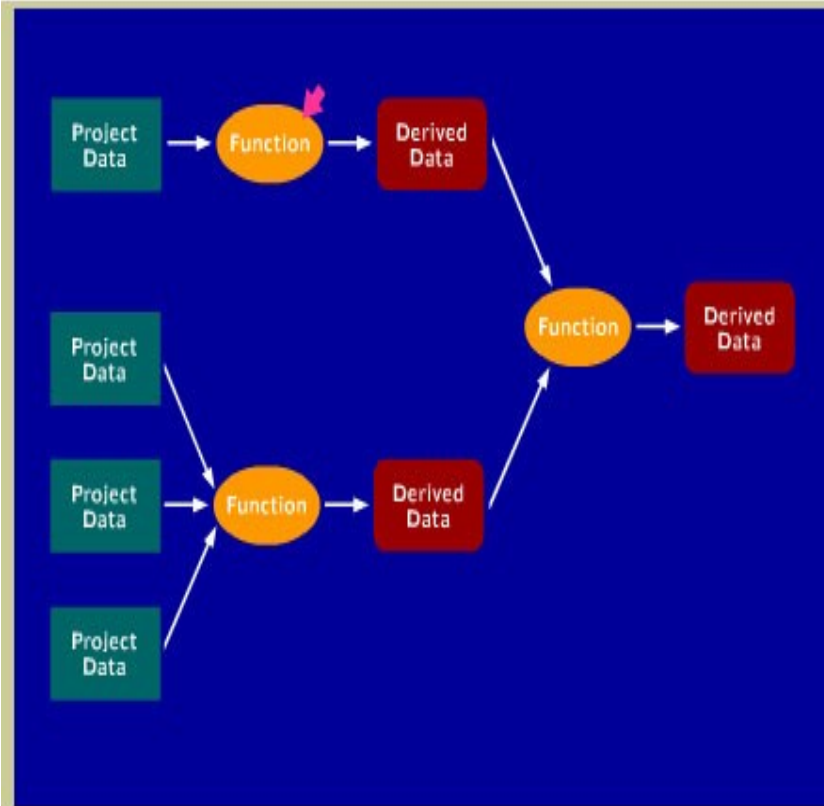

# ArcGIS 9 Model Builder

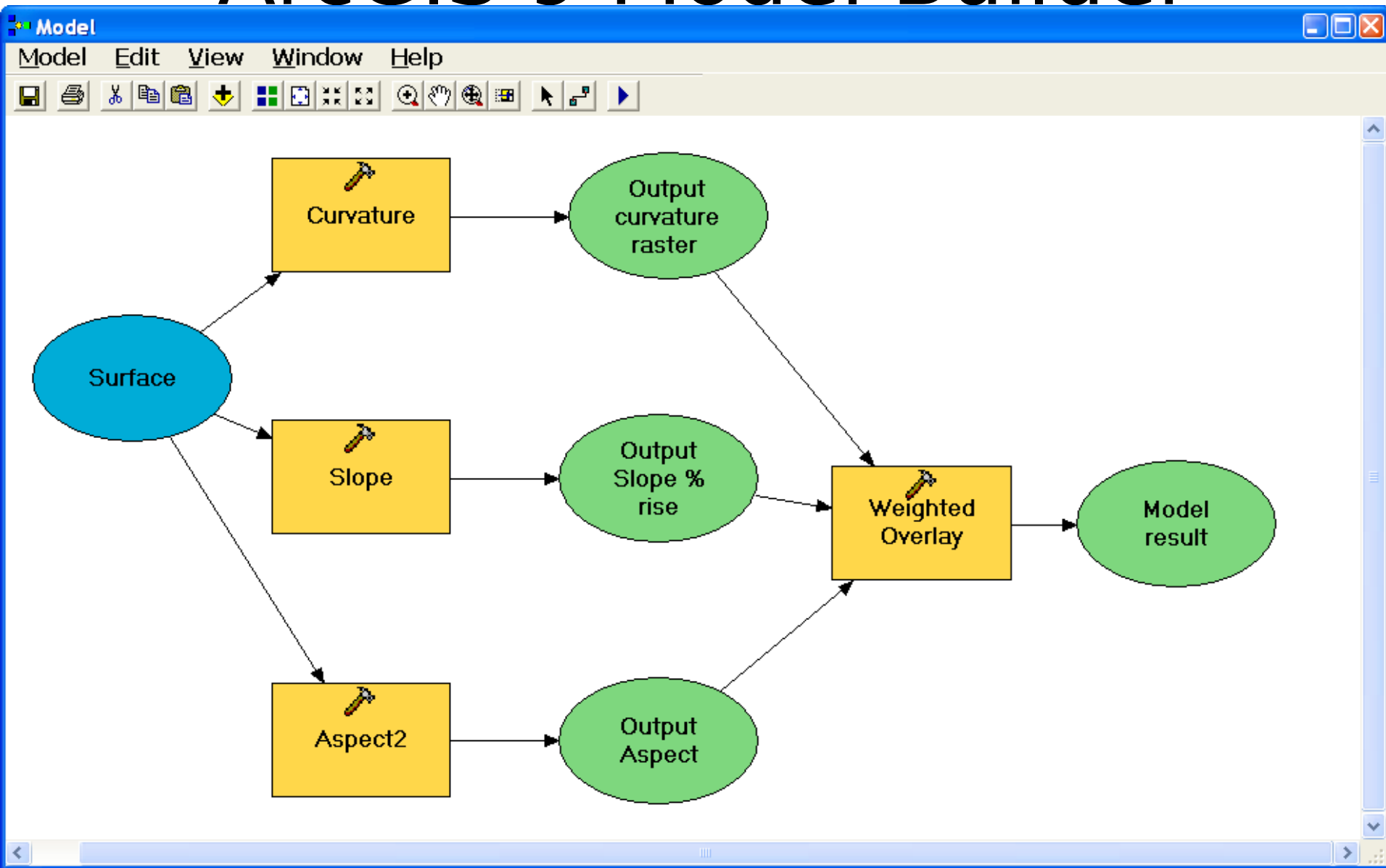

# ArcGIS 9 Model Builder

The screenshot displays the ArcGIS 9 Model Builder interface. The main window shows a map of a study area with a suitability result overlay. The map is color-coded, with green representing high suitability and yellow/orange representing lower suitability. The map includes features such as freeways, roads, streams, and a study boundary. The Layers panel on the left lists the following layers: Freeway, Roads, Lakes, Site Suitability Result (Value: High: 7.973233, Low: 0.000000), Streams, study\_boundary, Elevation, and Hillshade. The ArcToolbox on the bottom left shows the following categories: 3D Analyst Tools, Analysis Tools, Conversion Tools, Data Management Tools, Spatial Analyst Tools, SuitabilityToolbox, and Site Suitability. The Site Suitability model is currently selected in the SuitabilityToolbox.

The Site Suitability model diagram, shown in the top right, illustrates the workflow for calculating site suitability. The process starts with three input datasets: Elevation, Study Area Boundary, and Contours. The Elevation dataset is processed by the Calculate Shape tool, which outputs a Shape file. The Study Area Boundary dataset is processed by the Clip tool, which outputs a Clipped Features file. The Contours dataset is processed by the Clip tool, which outputs a Clipped Features file. The Shape file and the Clipped Features file from the first Clip tool are processed by the Extract by Attributes tool, which outputs a Low Slope file. The Clipped Features file from the second Clip tool and the Low Slope file are processed by the Euclidean Distance tool, which outputs a Class to Coverage file. Finally, the Class to Coverage file and the Low Slope file are processed by the Con tool, which outputs the final Result file.

The command window at the bottom shows the following text:

```
<Enter commands here>  
Executed (Con) successfully.  
End Time: Thu Jul 15 15:30:56 2004 (Elapsed Time: 1.00 secs)
```

The status bar at the bottom right indicates the coordinates 498460.08 3641938.60 Meters.

# Coordinate System and Projection

- Coordinate systems are defined by
  - number of dimensions (1, 2 or 3)
  - sequence/name of coordinate values (x, y, z)
  - unit scaling factor and system (meters)
  - origin of axes, direction of axes
- Coordinate systems can be based on a geodetic reference (datum) and a map projection

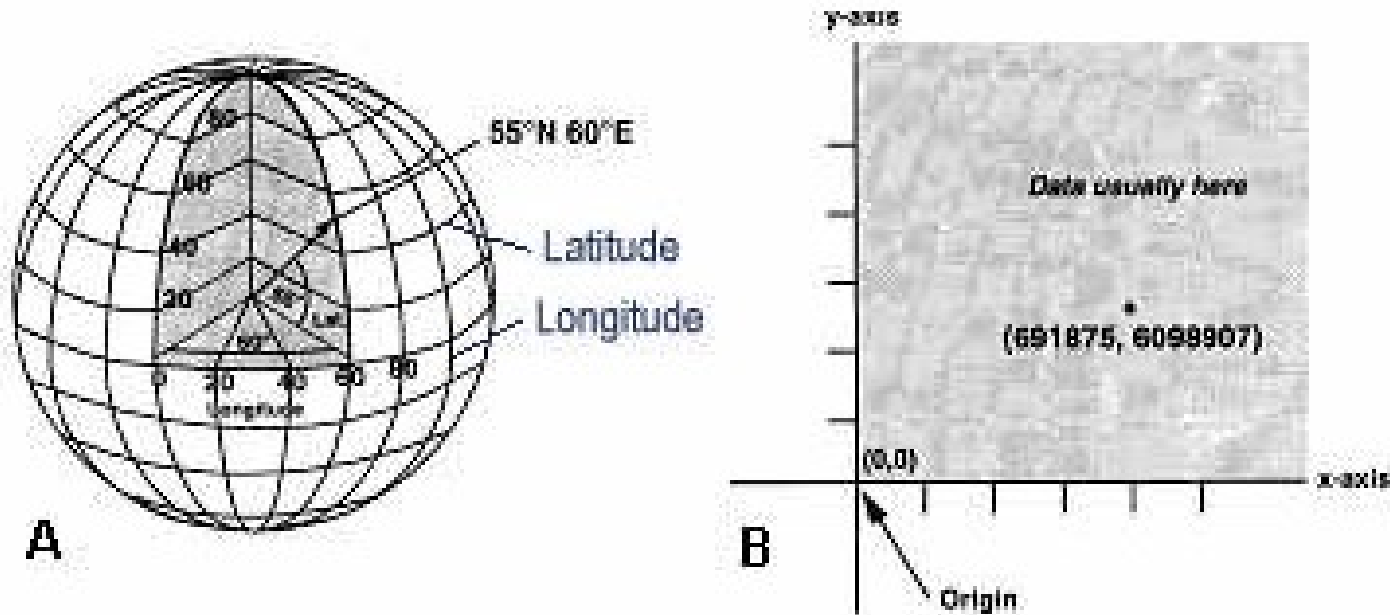



# Cartesian coordinate systems

- Named after mathematician René *Descartes*
- Mutually orthogonal system of straight axes as a complete reference framework for n-dimensional spaces
- Axes intersect at system's origin
- Metric, continuous measurement along axes
- Projections of spherical surfaces result in

# Geographical coordinates

- Specify position on a spherical surface relative to rotational (polar) axis and center
- Angular (polar) measurements
  - Latitude: angle from equatorial plane  $\pm 90^\circ$
  - Longitude: angle from Greenwich meridian  $\pm 180^\circ$
- For planar display on a map a „*projection transformation*“ is needed

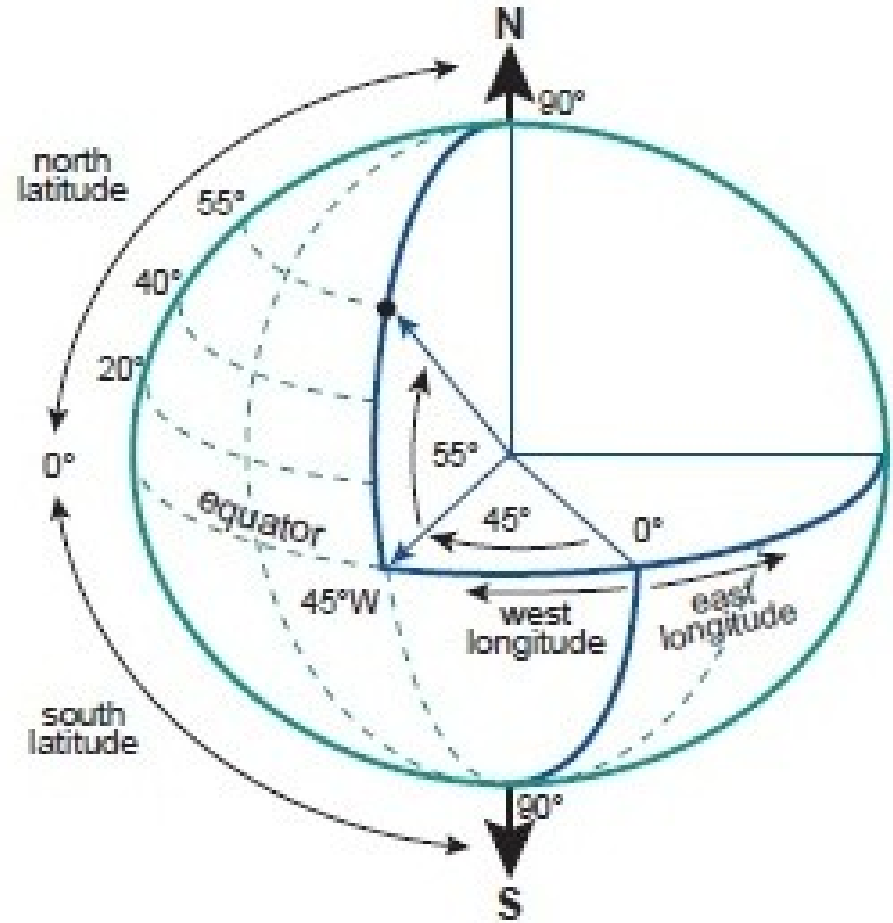

# Specific earth ellipsoids

- Over time, dimensions of ellipsoids have been refined and adjusted for best fit in different regions on Earth
- Usually specific ellipsoids are given the name of the mathematician / surveyor and are specific
  - semi-major and semi-minor axes

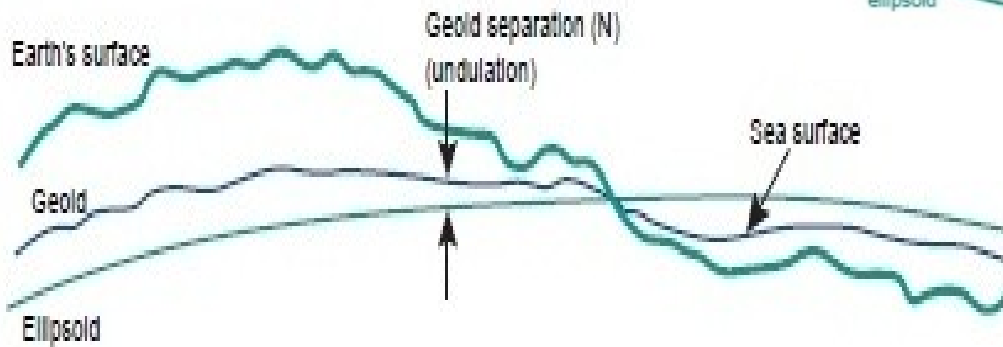
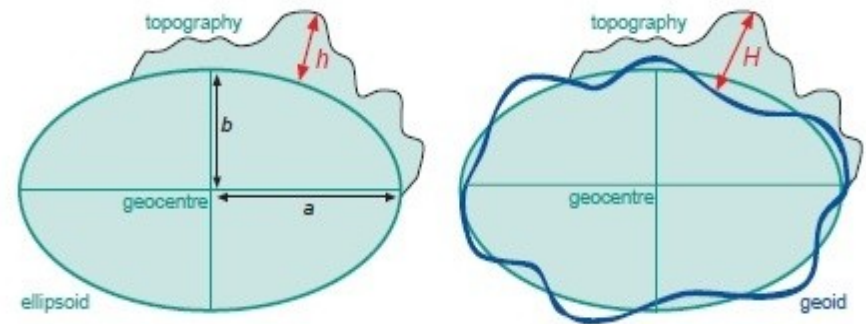

# Map projections

- A map projection is defined by
  - **name** of projection
  - **type** of projection (e.g. *cylindrical* - using different reference bodies)
  - **description** (applicable parameters depend on type of projection)
  - ellipsoid / **datum** parameters

# Type of Projection System

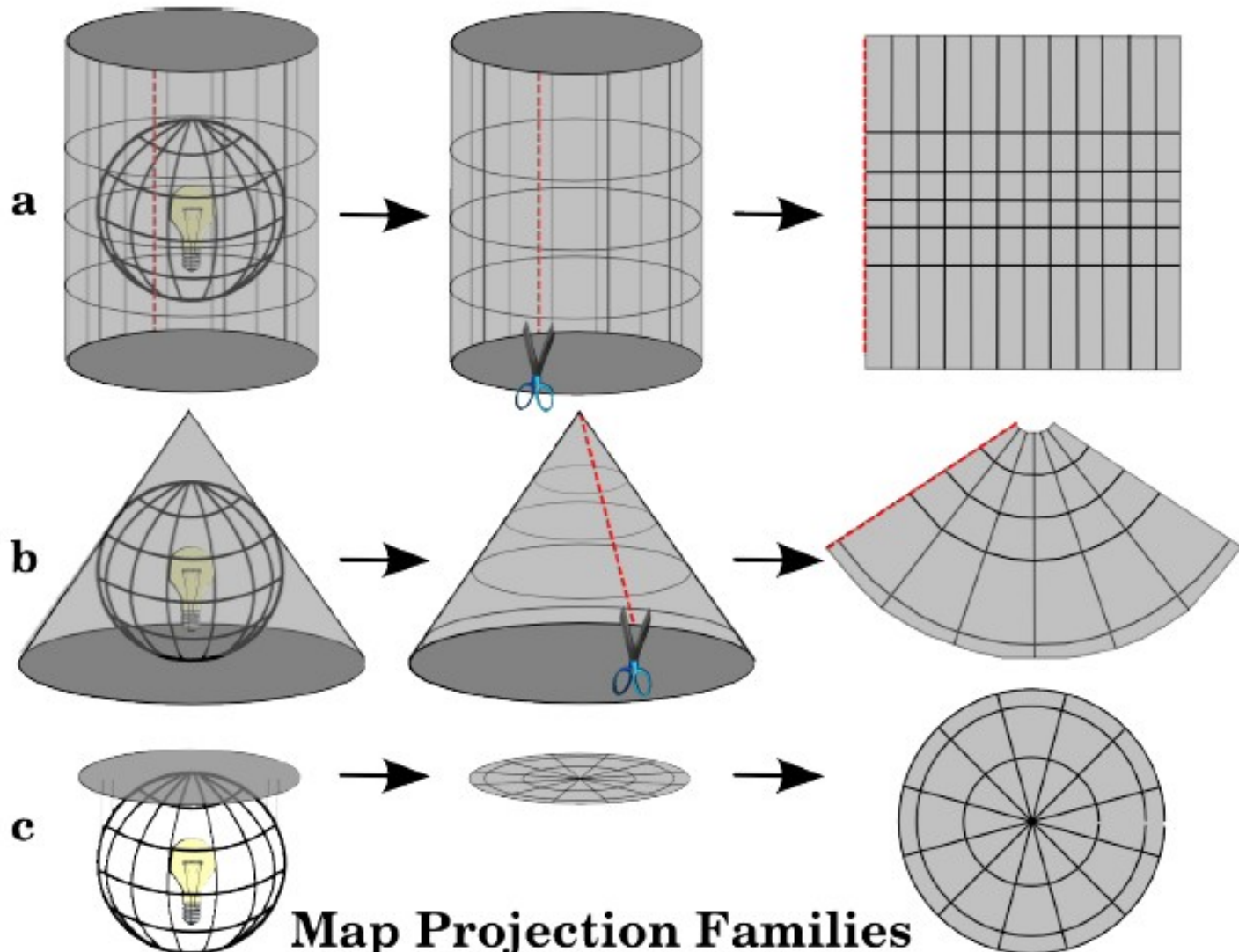

*Illustration 1: The three families of map projections. They can be represented by a) cylindrical projections, b) conical projections or c) planar projections.*

# Geographic Coordinate System

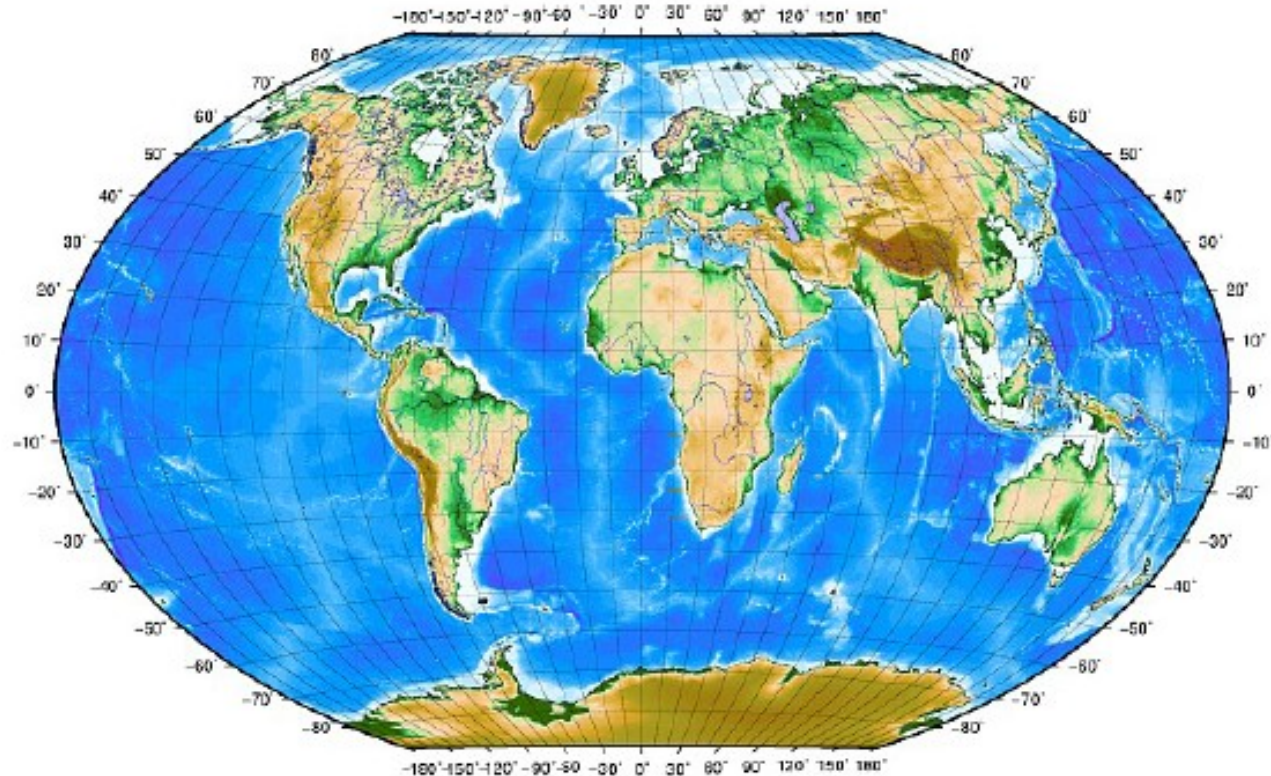
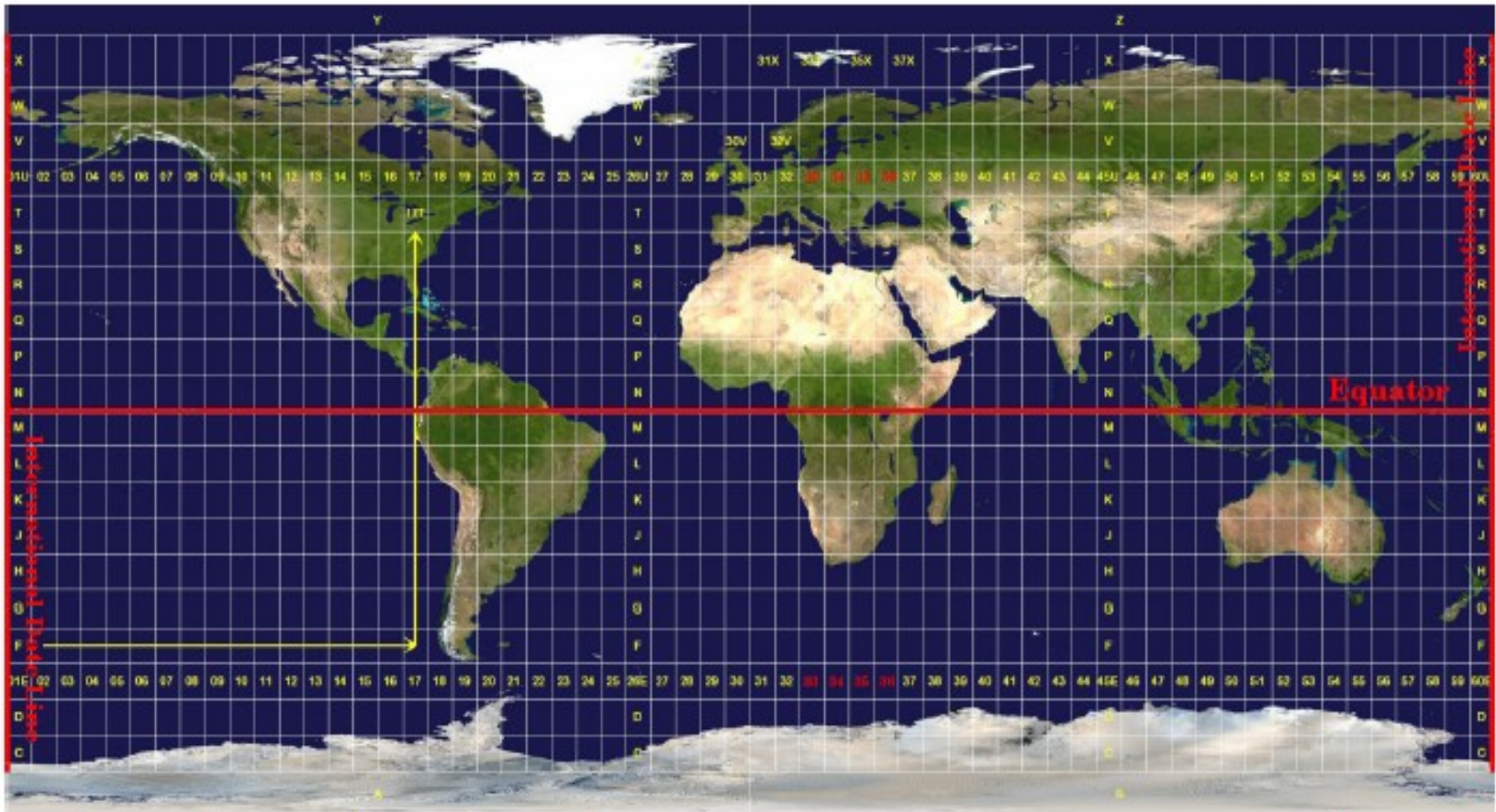

*Illustration 7: Geographic coordinate system with lines of latitude parallel to the equator and lines of longitude with the prime meridian through Greenwich.*

# UTM: Universal Transversal Mercator System

- Worldwide the most important projection system for large scale mapping
- Transversal („horizontal“) cylindrical proj.
- Cylinder is repositioned for better fit at every  $6^\circ$  longitude, starting from the international dateline going east:
  - Zones 1-60, each  $6^\circ$  wide around central meridian

# Projected Coordinate System- Universal Transverse Mercator(UTM)





# ESRI\* Object Models; Data Capture

\* Environmental Systems Research Institute

Attributes of candy sample_NAD27					
ID	Shape*	Id	Number	NAD27 East	NAD27 North
1	Point	01120		430921	4336632
1	Point	01123		431124	4337708
2	Point	01124		431325	4338128
3	Point	01125		431522	4338992
4	Point	01126		431653	4339751
5	Point	01127		432071	4339488
6	Point	01128		432263	4322511

Feature Class (spatial table)

Number	Age_Ma	1_sigma	Rx_Type	Size_kg
123	142	1.5	B_schist	3.4
124	136	2.0	G_schist	1.3
125				

Object Class (nonspatial table)

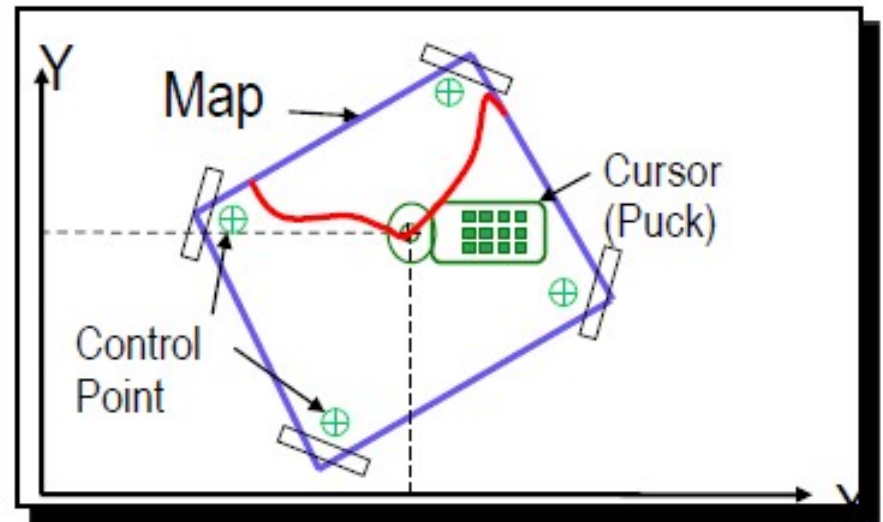

# Conceptual Models

Characterized all features or phenomena as:

⌘ Discrete objects; e.g. wells, roads, rock bodies, etc.

☑ ***Object-based models*** ←

⌘ Continuous phenomena; e.g. gravity, topography, temperature, snowfall, soil pH, etc.

☑ ***Field-based models***

# Outline



- ⌘ ESRI Software Family
- ⌘ ESRI Object Data Models
  - ⌘ History
  - ⌘ Data Organization – Physical Models
    - ⌘ Coverage
    - ⌘ Shapefile
    - ⌘ Geodatabase
- ⌘ Data Capture
  - ⌘ Digitizing
    - ⌘ “Heads Down”
    - ⌘ “Heads Up”
  - ⌘ Building Topology

ESRI = Environmental Systems Research Institute, Inc.

# Some ESRI History...

ESRI	Arc/Info	ArcView	ArcGIS
Date	1980-1999	1993-1999	2000 - present
Versions	1-7	1-3.2	8.0 – 10.2
Data Model	Coverage	Shapefile	Geodatabase
O.S.	Unix, PC DOS	Windows	Windows
Scripting Language	Arc Macro Language (AML)	Avenue Scripting	Vis. Basic for Appl. (VBA), Python
Database Software	Proprietary; Arc Tables	DBase	M.S. Access; ArcSDE for Oracle, etc.

# ArcGIS Desktop Levels

**PRODUCTS**  
(Licensing Levels)

**ArcView**



**ArcEditor**



**ArcInfo**



**DATA SOURCES**

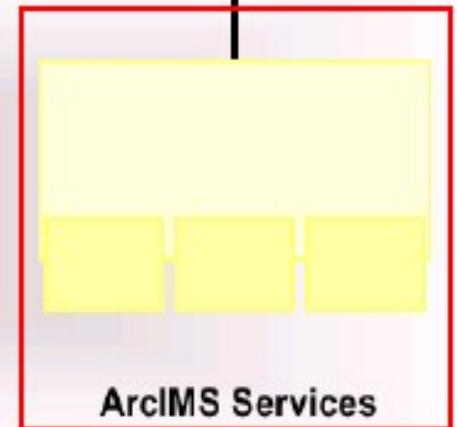
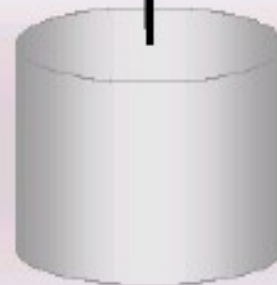
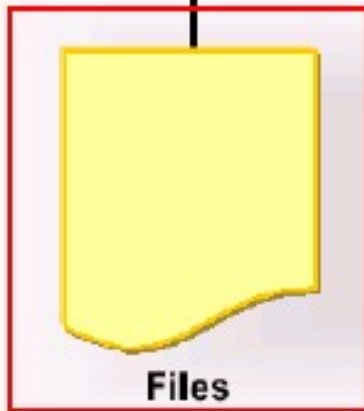

# ArcGIS Licensing Levels



- ⌘ **ArcView** – Make maps, do queries, some spatial analysis, some editing (shapefiles, personal geodatabases) – included with GTK ArcGIS Desktop
- ⌘ **ArcEditor** – plus edit multi-user geodatabases; more tools in toolbox
- ⌘ **ArcInfo** – full functionality; comes with ArcInfo Workstation (i.e. “legacy” ArcInfo v. 7). *UT D.G.S. licenses*

# Early ESRI Data Models

## Spatial Data

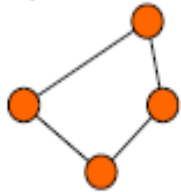

*Arc*

Geographic coordinates and attributes are stored in separate but linked files

## Aspatial Data

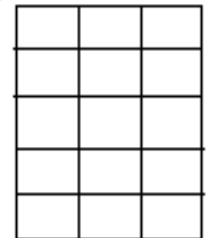

*Info*

### ⌘ Coverages

- ⊞ Developed for workstation Arc/Info ~ 1980
- ⊞ Complex structure, proprietary format
- ⊞ Attributes in *Info* tables

### ⌘ Shapefiles

- ⊞ Developed for ArcView ~ 1993
- ⊞ Simpler structure in public domain
- ⊞ Attributes in *dBase* (.dbf) tables

# Data Organization

## ⌘ Coverage

- ☒ Data split between coverage and INFO *folders*
- ☒ Common boundaries between polygons stored once
- ☒ Topology explicitly stored
  - ☒ Planar graph maintained

As in previous lecture

## ⌘ Shapefile

- ☒ Data divided among three or more *files* (.shp, .shx, .dbf, .sbx, .sbn, et al.)
- ☒ Common boundaries between polygons stored twice
- ☒ Topology created on-the-fly
  - ☒ Planar graph not required



1. Define GIS. Explain the functional components of GIS. Also list some application of GIS.
2. What is the difference between spatial and non-spatial data?
3. Define projection. Explain Nepal datum and Nepalese Projection System with all parameters.
4. What is DTM? Does TIN belong to a raster or a vector model and why?
5. What are the different type of spatial data capture techniques?
6. Explain different type of Raster models. What do you mean by raster overlay ? Give suitable examples?
7. What is proximity analysis? Explain the following vector functions with a suitable example (Spatial and tabular).
  - a. Merge
  - b. dissolve
  - c. clip
  - d. intersect
  - e. union
8. What is geo referencing? How do you geo reference an

9. Label vertex, node, arc and polygon for following figure and write down different vector models of given figure.

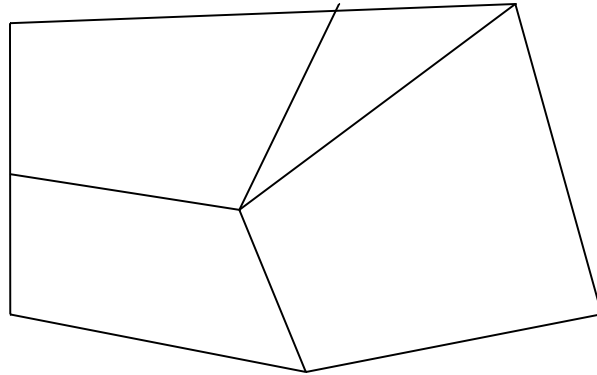

10. What is map layout? Prepare a template map layout indicating all the marginal information in a map.

11. Write down equivalent raster image of following vector data.

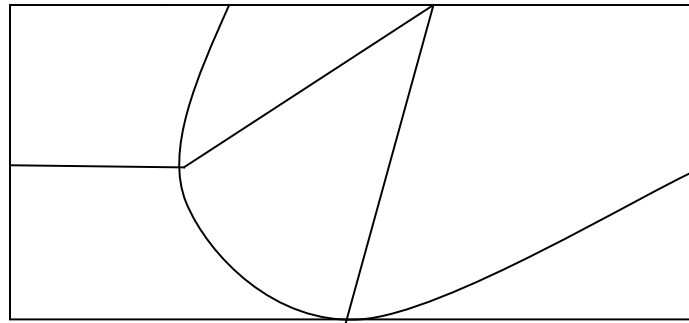

12. Add a new field called "class" to the following table. Write down the necessary code to convert feature code (F\_Code) to class.

where F\_code = 25100 is class = building

F\_code = 25110, class = agricultural area

F\_code = 25120, class = Forest

F\_code = 25130, class = water body

F\_code = 25140, class = grass

F\_code = 25150, class = Industrial area

Fid	Area	Perimet er	F_Code
0			25100
1			25110
2			25120
3			25130
4			25140
5			25150

13. Write down equivalent binary flat file for following raster line.

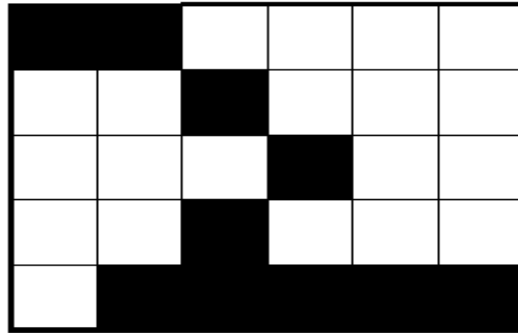

14. The followings are groundwater vulnerability and pesticide hazard map. Calculate pesticide risk map of same area if risk = vulnerability x hazard

5	6	1	1	1
5	5	4	4	3
5	4	6	5	4
5	6	6	7	4
3	6	7	7	5

10	11	11	15	15
10	12	12	15	15
10	10	14	17	10
14	15	14	15	10
13	12	12	15	15

Groundwater vulnerability map Pesticide hazard map

# **Global Positioning System (GPS)**

# Global Positioning System (GPS)

- The **Global Positioning System (GPS)** is a space-based navigation system that provides location and time information in all weather conditions, anywhere on or near the Earth where there is an unobstructed line of sight to four or more GPS satellites. The system provides critical capabilities to military, civil, and commercial users around the world. The United States government created the system, maintains it, and makes it freely accessible to anyone with a GPS receiver.
- In addition to **American system**, there are other many GPS system like the **Russian equivalent (GLONASS)**, the **European equivalent (GALILEO)**, the **Chinese equivalent (BeiDou-2)**, or other similar systems (**GNSS**).

## **Global Positioning System (GPS)**

- Installed and maintained by U.S. Dept. of Defense
- Worldwide radio navigation system w/ constellation of GPS satellites and their ground stations
- NAVSTAR satellites (NAVigation Satellite Timing and Ranging)
- First launch - 1978
- Can be used for any application that requires location information.

The Global Positioning System (GPS) was first launched in 1978 by the Department of Defense. The system includes a constellation of satellites (NAVSTAR) and ground control stations. GPS can be used by anyone and for any application that requires location information.

## Components of GPS

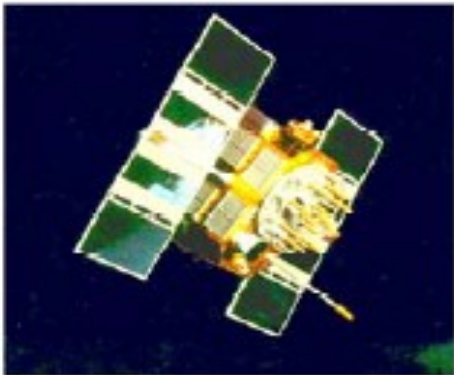

NAVSTAR satellites



GPS receiver

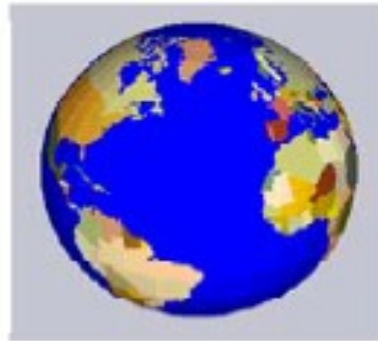

Earth's surface

GPS requires three components: Direct connection to at least 4 NAVSTAR satellites, a GPS receiver, and location on or near (airplanes) the earth's surface.



# Components of GPS

- **Space Segment (GPS satellites)**
  - Navigation Satellites, which have an average 8.5 years lifespan, are renewed and evolve with technology. As of February 2016, there are 32 satellites at 20,200 kilometers (12,600 miles) above the earth in the GPS constellation, 31 of which are in use. The additional satellites improve the precision of GPS receiver calculations by providing redundant. The satellites are spaced so that from any point on earth, at least four satellites (typically 5 to 8) will be above the horizon. There are four active satellites in each of six-orbital planes. Satellites orbit with a period of 11h58' at an angle of 55° to the Equator to ensure coverage of polar regions and 60° to other orbits. Powered by solar cells, the satellites continuously orient themselves to point their solar panels toward the Sun and their antennas toward Earth. Each satellite contains one computer, four atomic clocks and a radio and is able to continually broadcast its changing position and time.
- **Control Components (GPS ground control stations)**
  - The ground control component includes the master control station at Falcon Air Force Base, Colorado Springs , Colorado and monitor stations at Falcon AFB, Hawaii , Ascension Island in the Atlantic , Diego Garcia in the Indian Ocean , and Kwajalein Island in the South Pacific. The control segment uses measurements collected by the monitor stations to predict the behavior of each satellite's orbit and atomic clocks. The prediction data is linked up to the satellites for transmission to users. The control segment also ensures that GPS satellite orbits remain within limits and that the satellites do not drift too far from nominal orbits.
- **User Component (GPS receivers)**
  - When we buy a GPS, we are actually buying only the GPS receiver and get free use of the other two main components, worth billions of dollars. The user segment (also called GPS receiver) is composed of hundreds of thousands of U.S. and allied military users of the secure GPS Precise Positioning Service, and tens of millions of civil, commercial and

# Space Segment

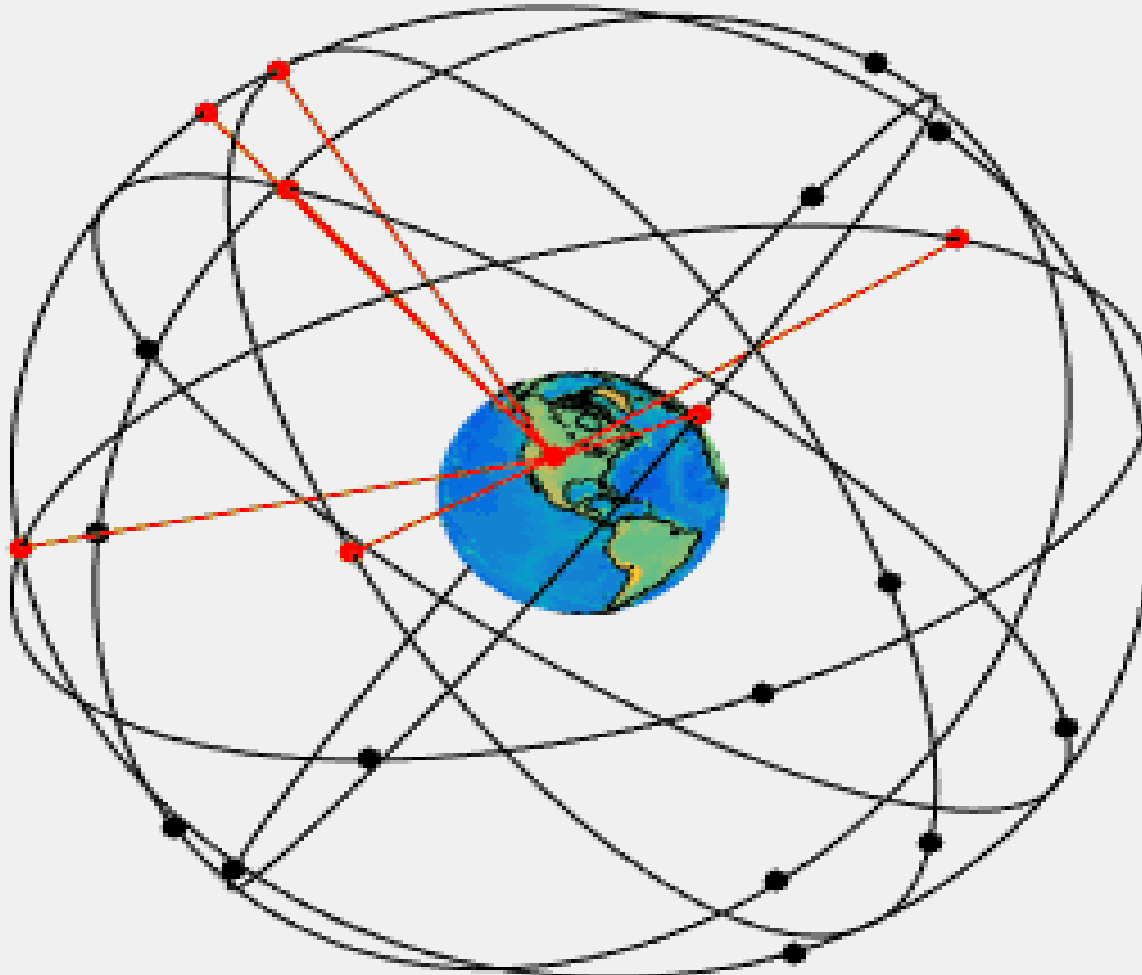

7 visible satellites

# Control Segment



Locations of GPS ground monitoring stations. These stations controls and monitors the satellite orbits and function.

# User Segment



GPS receivers come in a variety of formats, from devices integrated into cars, phones, and watches, to dedicated devices such as these.



Hand-held receivers



A taxi equipped with GPS

# How GPS works?

GPS uses triangulation to determine a user's

Distance = Speed x Travel Time

1. GPS signals are a radio signal, therefore they travel at the speed of light
2. If we know the time the signal was sent and the time the signal was received we can work out travel time.
3. By subtracting the sent time from the received time, we can determine the travel time
4. Now we can multiply travel time by the speed of light and we can determine distance

To determine distance, both the satellite and GPS receiver generate the same pseudocode at the same time. The satellite transmits the pseudocode which is received by the GPS receiver. The receiver is still producing the pseudocode while the satellite's code is travelling through the sky. The 2 signals are eventually compared and the difference between the 2 signals is the travel time.

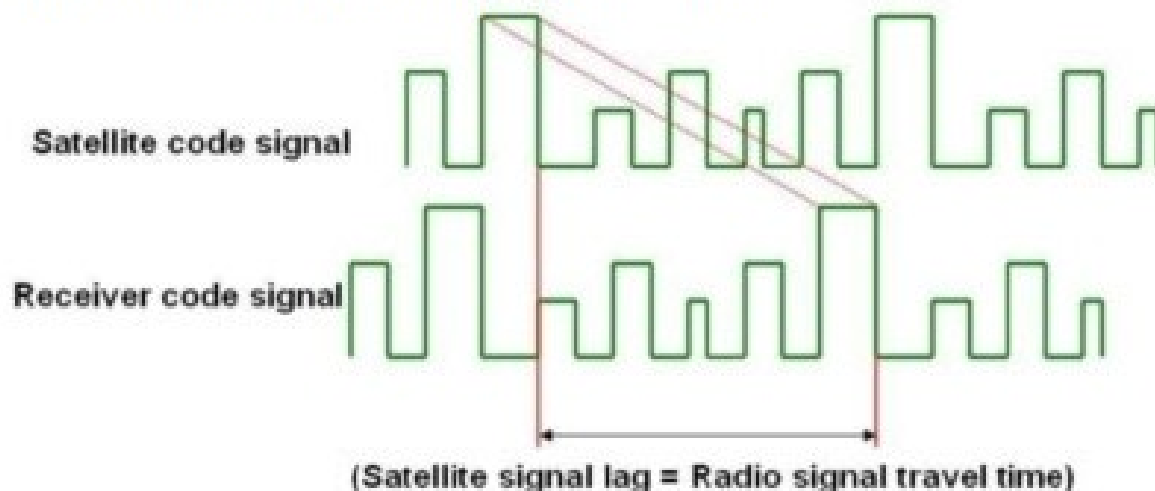

# How GPS works ?

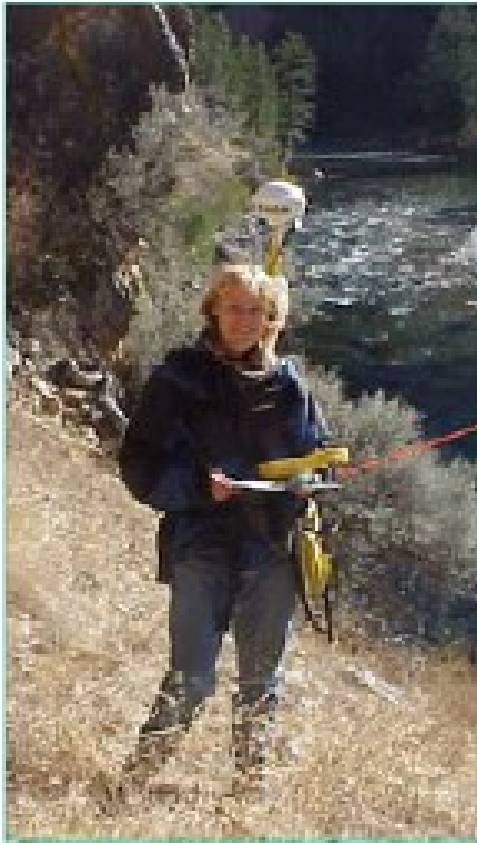

- GPS receivers calculate their position by measuring the time it takes for the signal to travel from the satellites to the receiver
- Satellite signals require a direct line to the GPS receiver
- Signals can not go through water, soil, walls or others

## How GPS works - 5 steps

- Accurate measure of time for signal to travel from satellite to receiver
- Speed of light  $\times$  travel time = distance
- Distance measurements to 4 satellites is necessary to compute a 3-D position through triangulation
- Knowledge of satellite positioning
- Corrections due to atmospheric influences and other errors

The time it takes from the GPS signal to travel from the satellite to the receiver is measured and then converted to distance by multiplying with the speed of light. Distance measurements from 4 satellites is necessary to compute a 3-d position (including a reasonably accurate measure of elevation). A lower accuracy 2-D position can be computed from distance measurements from three satellites. Differential correction can be applied to the signal to correct for atmospheric and other errors. We will talk more about differential correction later in this lecture.

## A third measurement...

*A third measurement narrows down our position to just two points*

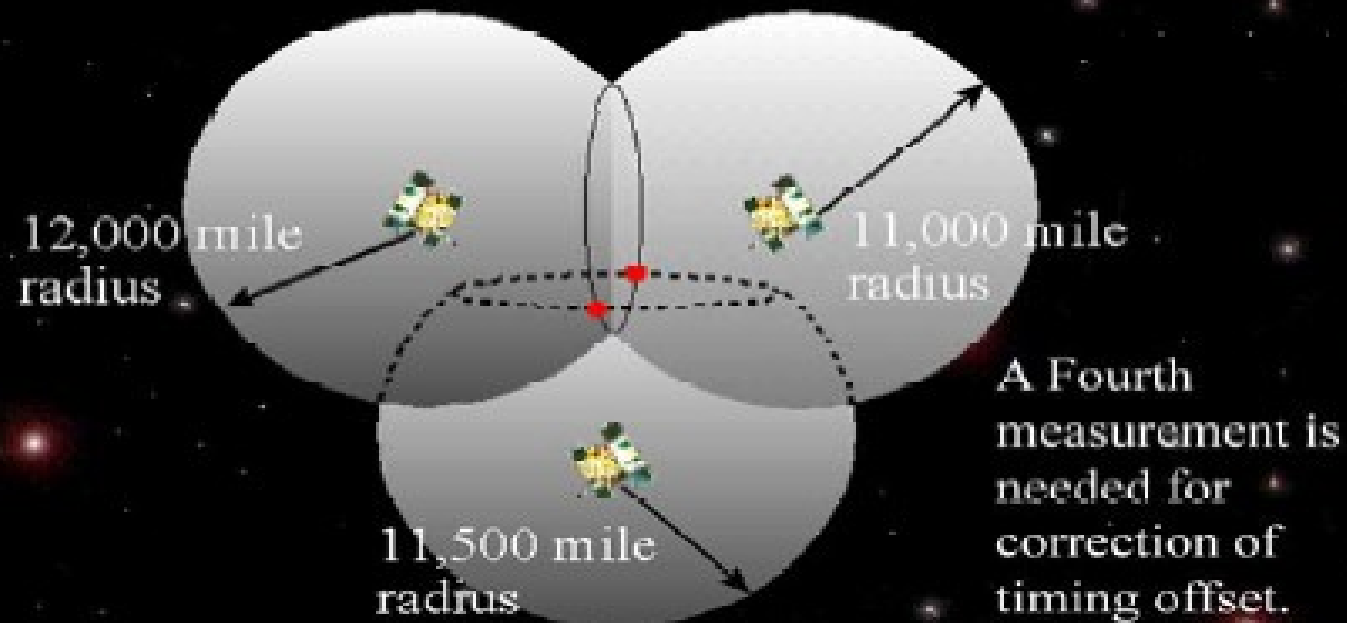

<http://www.montana.edu/places/gps/>

A third measurement narrows down the position to only two points. A fourth measurement narrows down the location to only one location. You can get a reasonable (less accurate) estimate of location with only three satellite measurements, however four satellite measurements are necessary for computation of altitude.



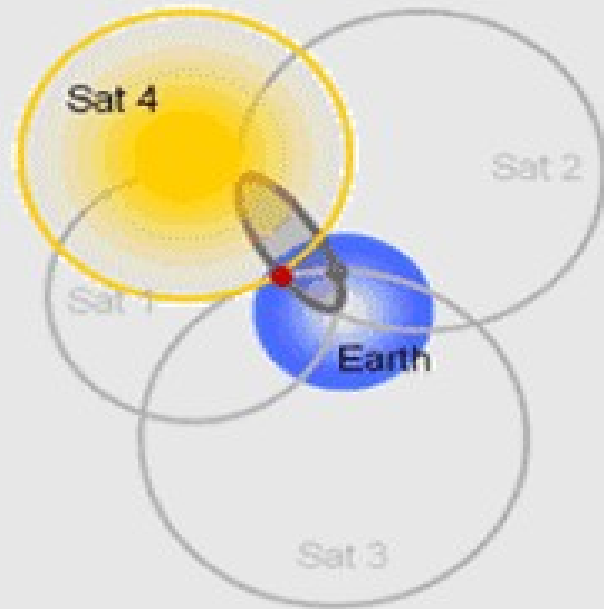
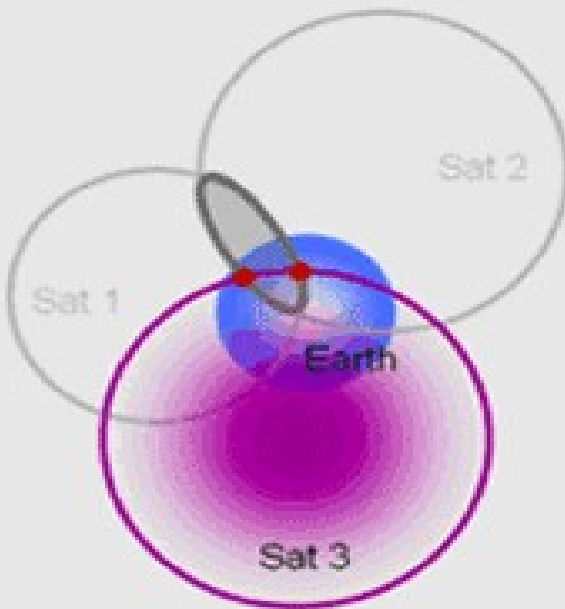
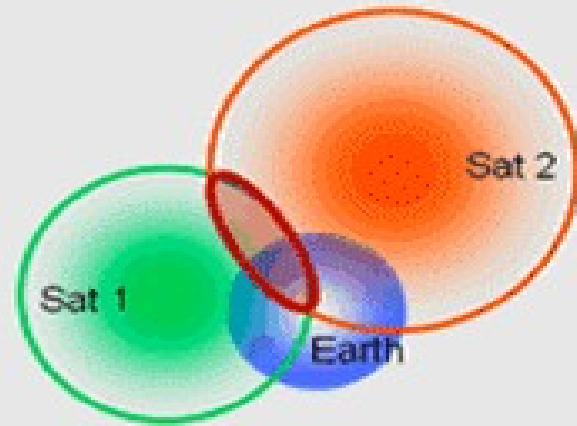
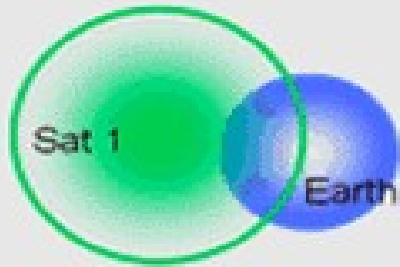

## GPS errors

- Atmospheric effects
- Measurement noise
- Ephemeris errors
- Satellite clock drift
- Multi-path effects
- Satellite geometry
- Selective Availability (turned off May 2000)

Many contributing factors add to the error associated with acquisition of a GPS location. In the next few slides you will explore the sources and influence of the different errors on the total GPS error.

The last bullet in the slide addresses the error introduced by ‘Selective Availability’. Selective Availability was a ~100 m error introduced to the GPS signal by the Department of Defense. Selective Availability was turned off in May 2000, and is currently not affecting the accuracy of GPS receivers.

## Atmospheric refraction

### Ionospheric & Tropospheric Refraction

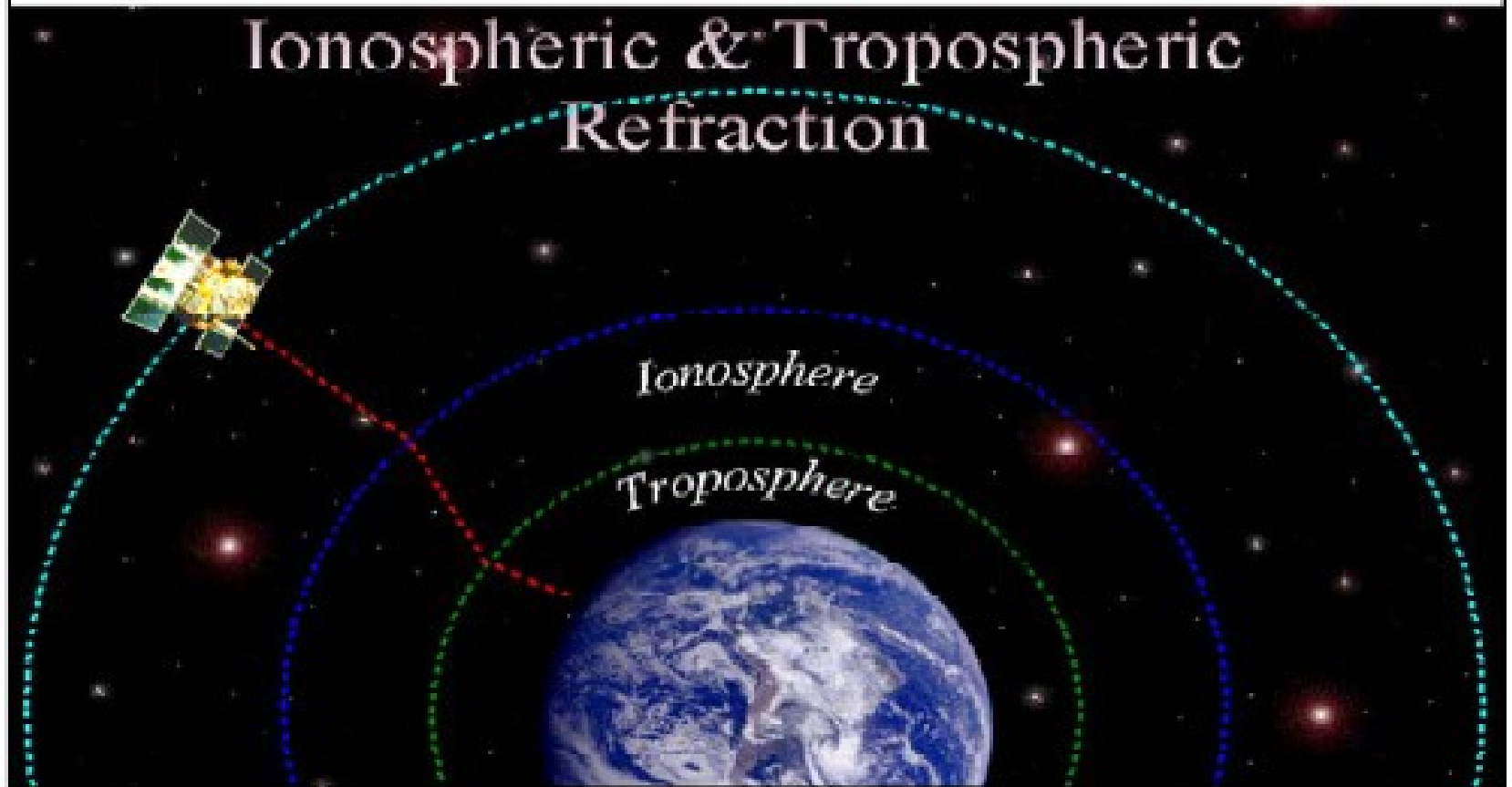

The ionosphere and troposphere both refract the GPS signals. This causes the speed of the GPS signal in the ionosphere and troposphere to be different from the speed of the GPS signal in space. Therefore, the distance calculated from "Signal Speed x Time" will be different for the portion of the GPS signal path that passes through the ionosphere and troposphere and for the portion that passes through space.

## Multipath

### Multipath

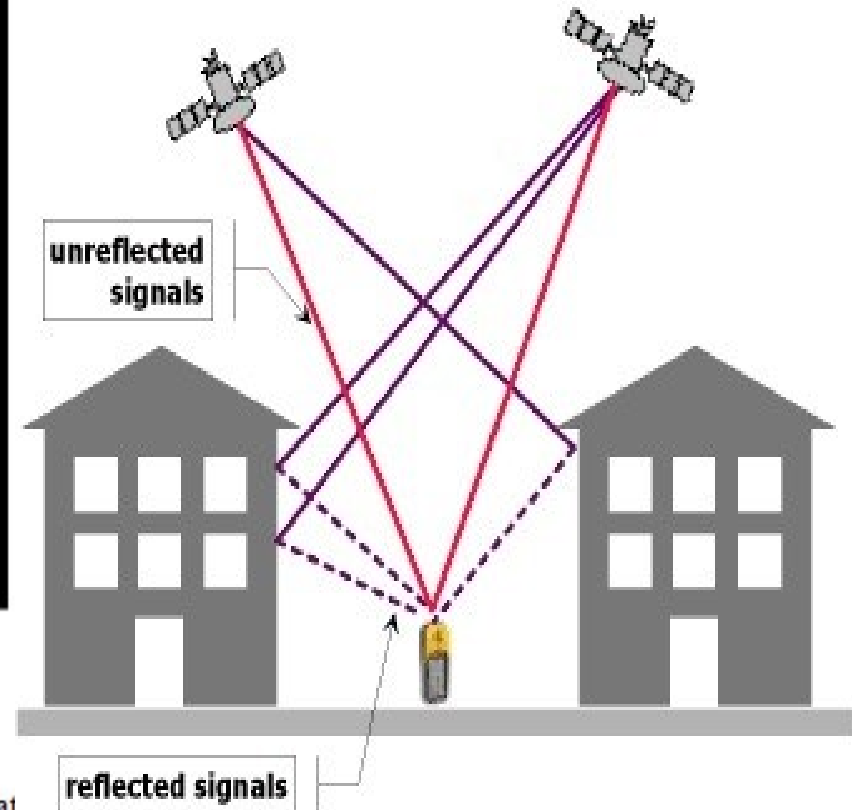

A GPS signal bouncing off a reflective surface prior to reaching the GPS receiver antenna is referred to as multipath. Because it is difficult to completely correct multipath error, even in high precision GPS units, multipath error is a serious concern to the GPS user.

# Satellite geometry

## PDOP - Position Dilution of Precision

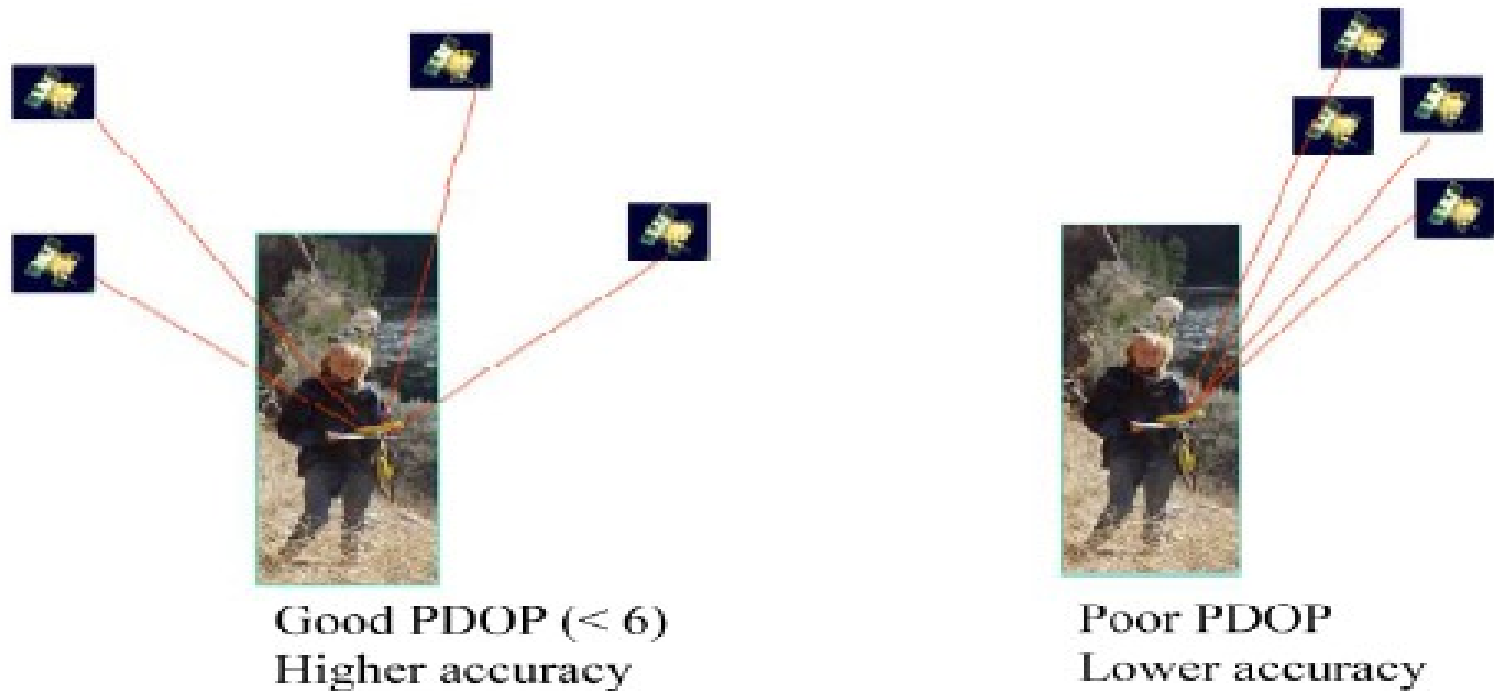

PDOP is an indicator of the quality of the geometry of the satellite constellation. Your computed position can vary depending on which satellites are used for the measurement. Different satellite geometries affect the errors. A greater angle between the satellites lowers the PDOP, and provides a better measurement. A higher DOP indicates poor satellite geometry, and an inferior measurement configuration.

PDOP under good conditions is below 6. The accuracy specification for a high end GPS unit is only valid when the PDOP is below a specified value (usually 6).

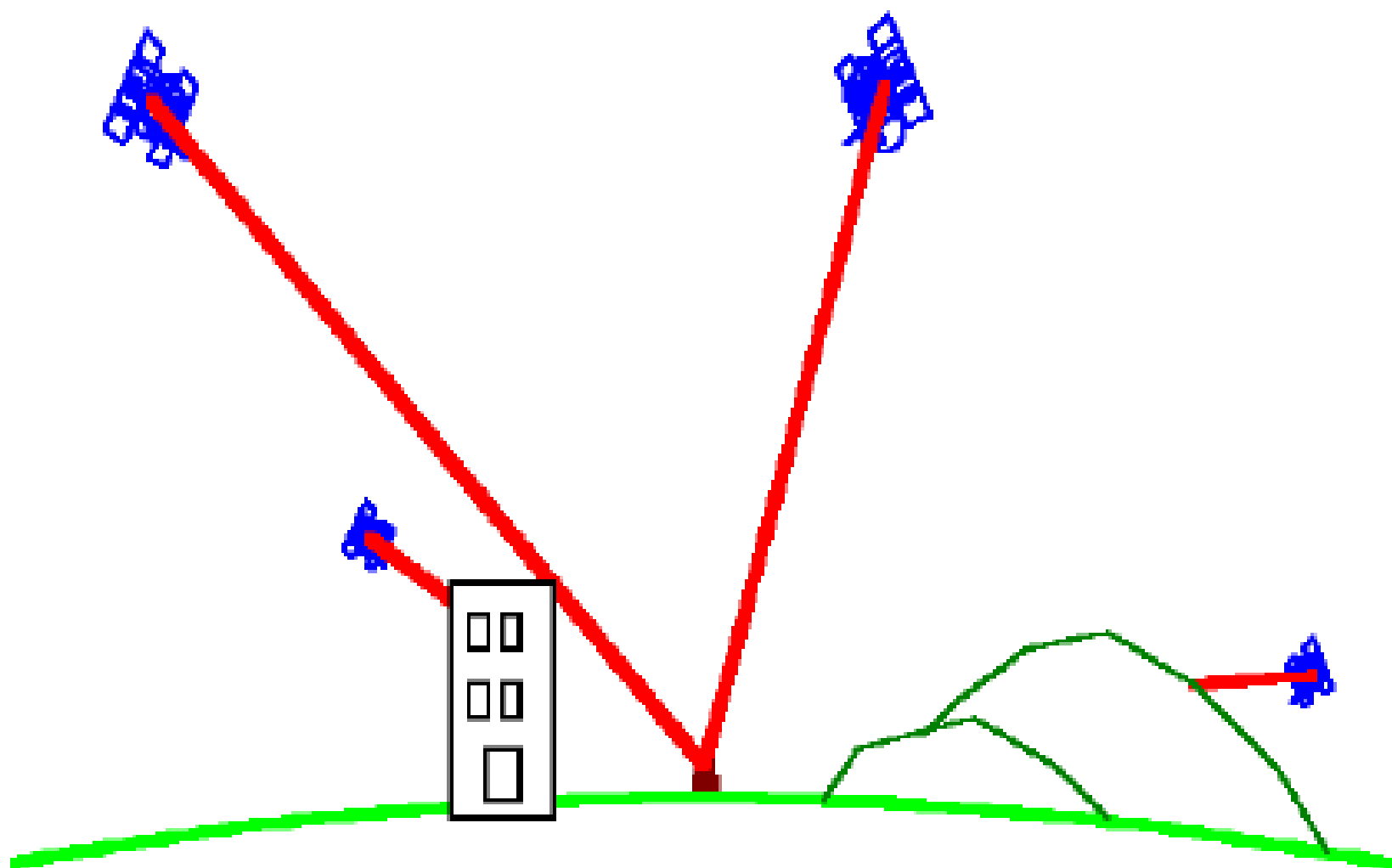

**GOOD GDOP- BAD VISIBILITY**

## GPS error budget

Source	Uncorrected Error Level
Ionosphere	0-30 meters
Troposphere	0-30 meters
Measurement Noise	0-10 meters
Ephemeris Data	1-5 meters
Clock Drift	0-1.5 meters
Multipath	0-1 meter

*(Selective Availability 0-70 meters) removed in May 2000*

The error levels for different sources of GPS error are listed in the table above. Selective Availability was an error introduced by the Department of Defense, however this error was turned off in May of year 2000.

Ephemeris data refers to imperfections in the satellite orbits.

# Differential GPS

....is used to correct for errors



- 1) Real-time differential correction
- 2) Post-processing

Differential GPS (DGPS) incorporates a series of techniques to account for some of the GPS errors. Differential GPS can be applied 'on the fly' (real-time differential GPS) or post-processing differential correction (correction applied to the GPS data after it has been collected).



---

## Differential GPS

---

- Involves use of two receivers - one that's stationary (reference) and another rover
- errors are a compounding of factors, but receivers within 100km usually have same errors
- stationary receiver sits on a known location and back calculates what the timing should be, compares with what they are and develops "error correction" factor
- corrections are transmitted to rovers
- or differential corrections are made after field data collection - post-processing differential correction

# **Remote Sensing (RS)**

# Remote Sensing

6

- Remote sensing has been variously defined but basically it is the art or science of **telling something** about an object **without touching** it. (Fischer et al., 1976, p. 34)
- Remote sensing is the **acquisition of physical data** of an **object** without **touch or contact**. (Lintz and Simonett, 1976, p. 1)
- Remote sensing is the **observation** of a **target** by a device separated from it by **some distance**. (Barrett and Curtis, 1976, p. 3)
- The term “remote sensing” in its broadest sense merely means “**reconnaissance at a distance**.” (Colwell, 1966, p. 71)
- Remote sensing is the art, science and technology of **obtaining reliable information** about physical **objects and the environment**, through the process of recording, measuring and interpreting imagery and digital representations of **energy patterns** derived from **noncontact sensor systems** (Lecture Note by Wataru, 2009)

# Remote Sensing

7

- Remote sensing is the **science of deriving information** about an **object** from **measurements** made at a **distance** from the object, i.e., **without actually coming in contact with it**. The quantity most frequently measured in present-day remote sensing systems is the **electromagnetic energy** emanating from objects of interest, and although there are other possibilities (e.g., seismic waves, sonic waves, and gravitational force), our attention . . . is focused upon systems which measure electromagnetic energy. (D. A. Landgrebe, quoted in Swain and Davis, 1978, p. 1)
- Remote sensing is the practice of **deriving information** about the **Earth's land** and water surfaces using images acquired from an **overhead perspective**, using **electromagnetic radiation** in one or more regions of the electromagnetic spectrum, **reflected or emitted** from the Earth's surface. (James B. Campbell, Randolph H. Wynne (2011): Introduction to Remote Sensing)

**Is remote sensing limited to use of electromagnetic radiation !!!?**

# What is being detected?

- Electromagnetic (EM) radiation
- Day – reflected and emitted
- Night – emitted
- Contrast with other geophysical techniques (e.g., acoustic, seismic)

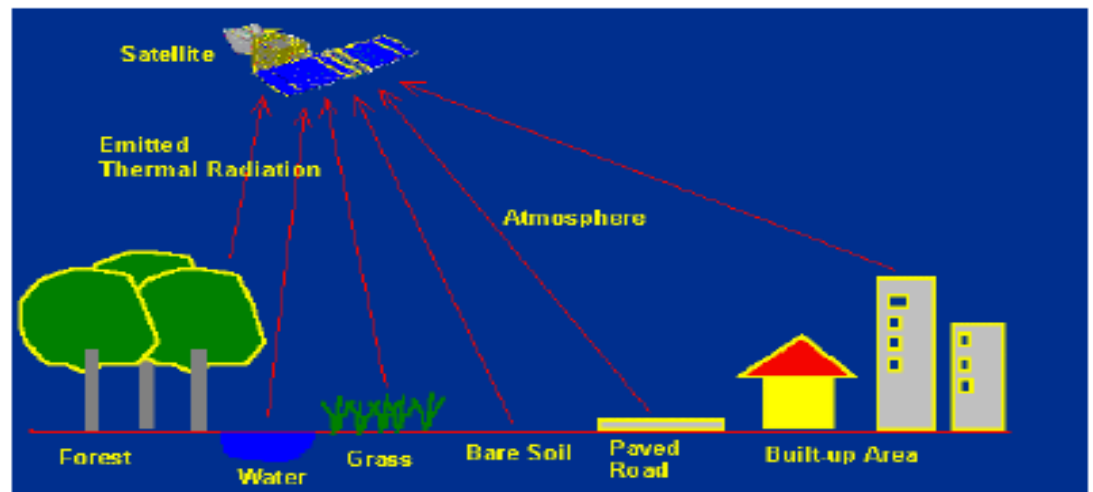
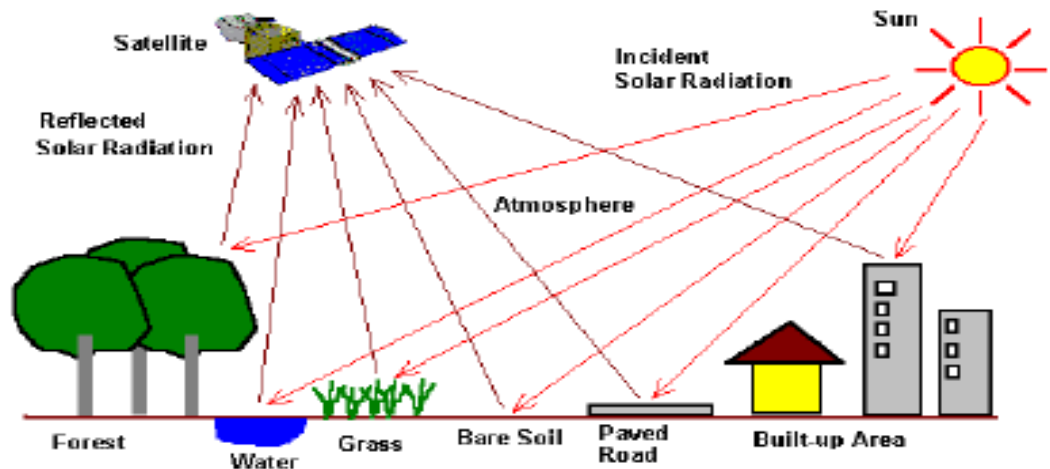

By recording emitted or reflected radiation and applying knowledge of its behaviour as it passes through the Earth's atmosphere and interacts with objects, remote sensing analysts develop knowledge of the character of features such as vegetation, structures, soils, rock, or water bodies on the Earth's surface.

# Various Steps in RS

23

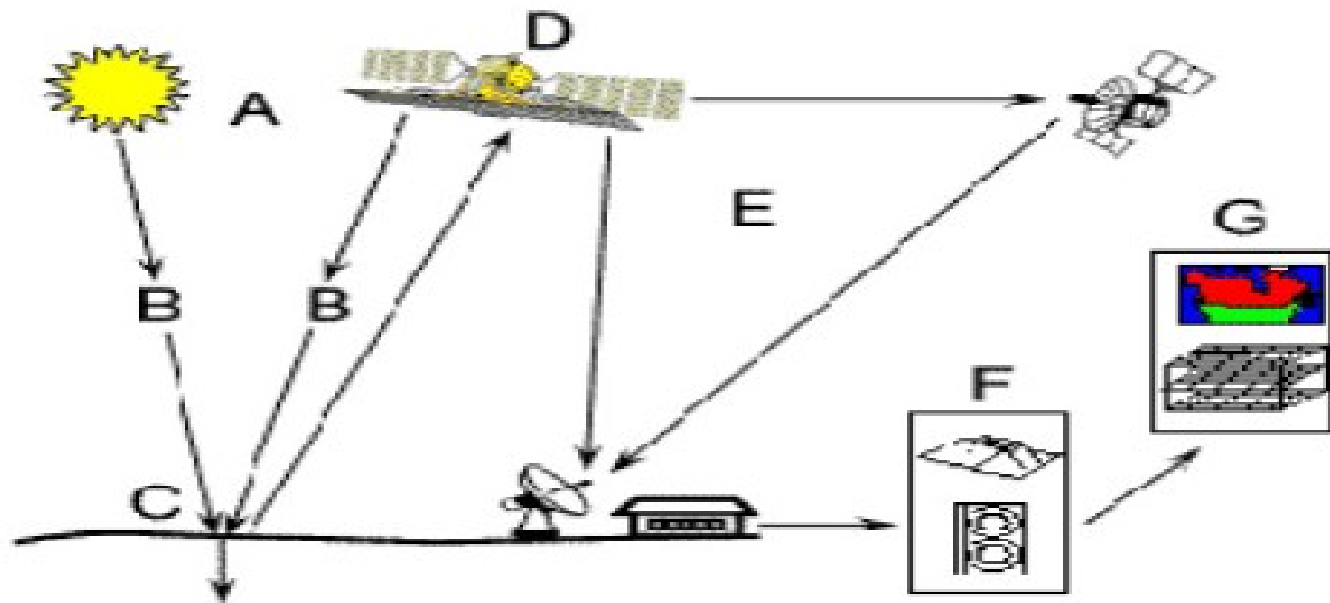

© CCRS / CCT

- (A) Energy Source
- (B) Radiation and the Atmosphere
- (C) Interaction with the Target
- (D) Recording of Energy by the Sensor
- (E) Transmission, Reception, and Processing
- (F) Interpretation and Analysis
- (G) Application

# Electromagnetic waves

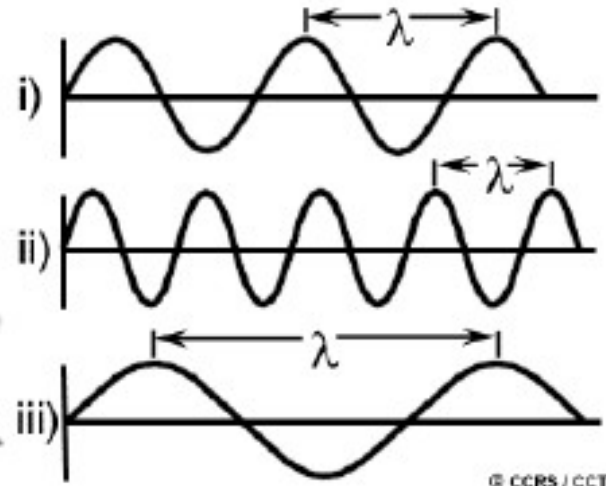
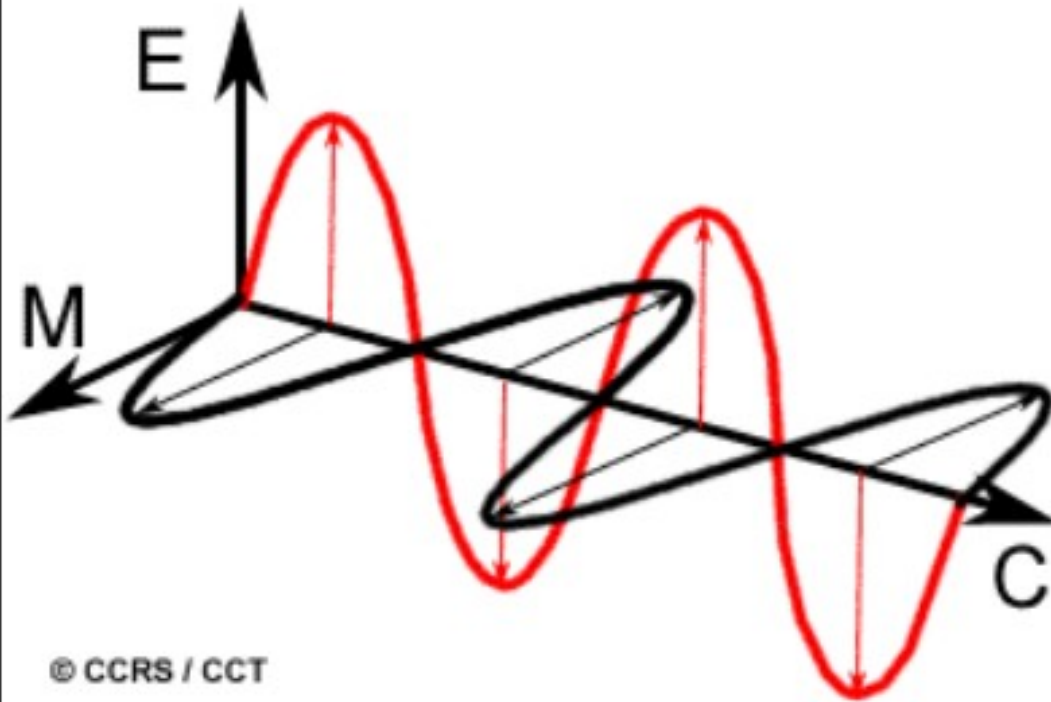

© CCRS / CCT

- Electric field (E)
- Magnetic field (M)
- Perpendicular and travel at velocity,  $c$  ( $3 \times 10^8 \text{ ms}^{-1}$ )
- Characterized by wavelength ( $\lambda$ ), frequency and energy

# Electromagnetic (EM) Spectrum

18

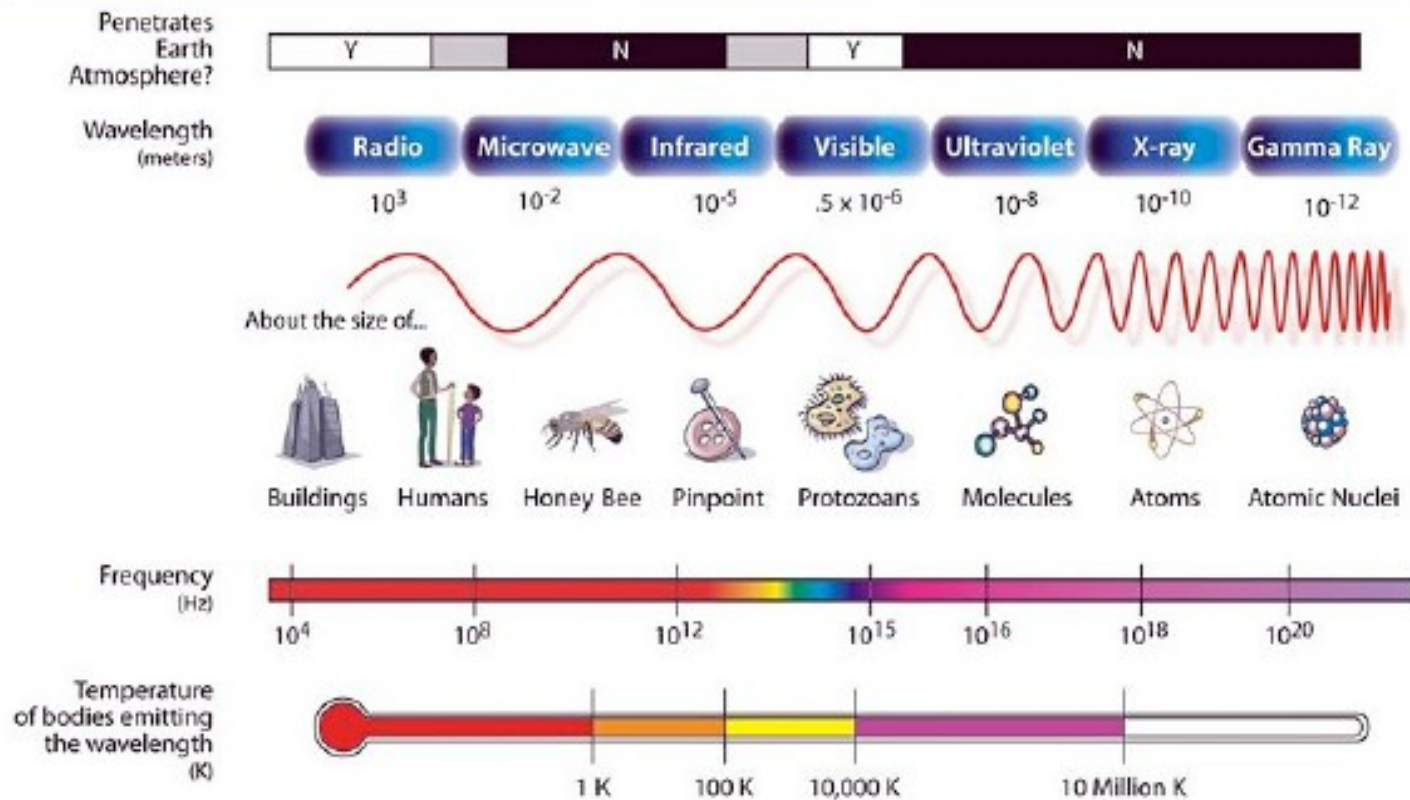

The most familiar form of EMR is visible light, which forms only a small (but very important) portion of the full EM spectrum.

The large segments of this spectrum that lie outside the visible range require our special attention because they may behave in ways that are quite foreign to our everyday experience with visible radiation.



# Atmospheric Windows

19

- Earth's atmosphere is by no means completely transparent to electromagnetic radiation because the gases ( $O_3$ ,  $O_2$ ,  $CO_2$  &  $H_2O$ ) together form important barriers to transmission of electromagnetic radiation through the atmosphere
- Atmosphere selectively transmits energy of certain wavelengths; those wavelengths that are relatively easily transmitted through the atmosphere are referred to as *atmospheric windows*

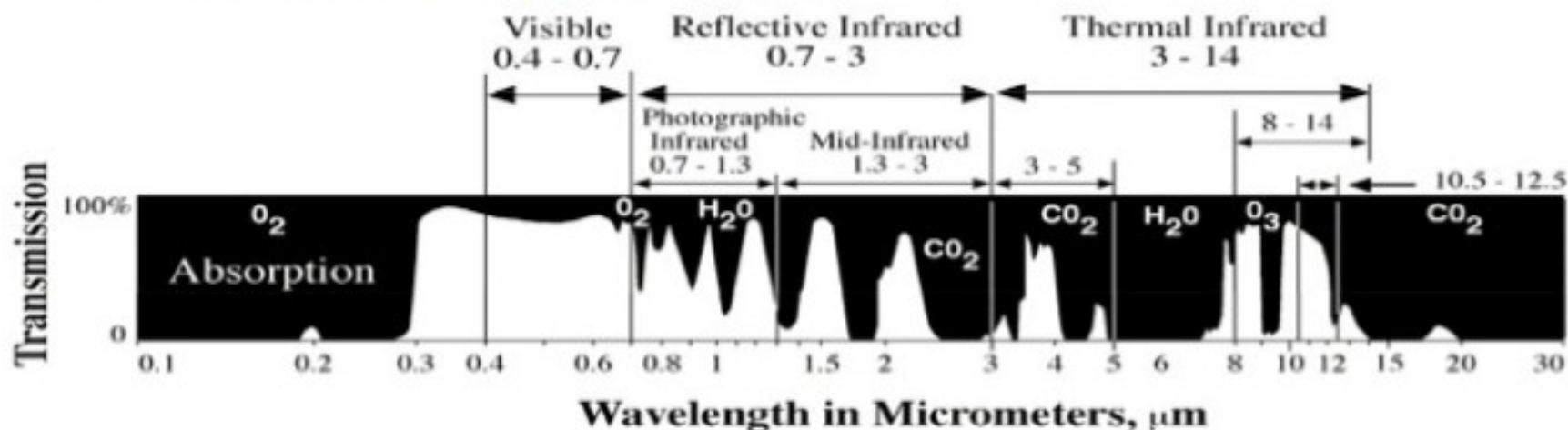

**Atmospheric windows are vitally important to the development of sensors for remote sensing**

# Type of Remote Sensing (RS)

20

## □ Passive RS

### ■ Natural (EMR from Sun)

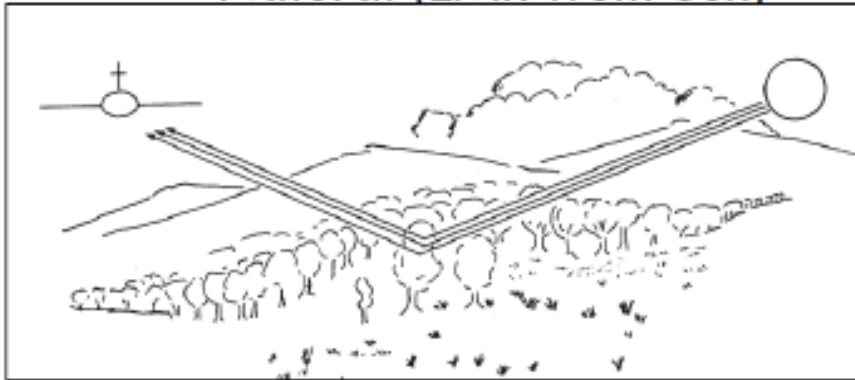

RS using reflected solar radiation

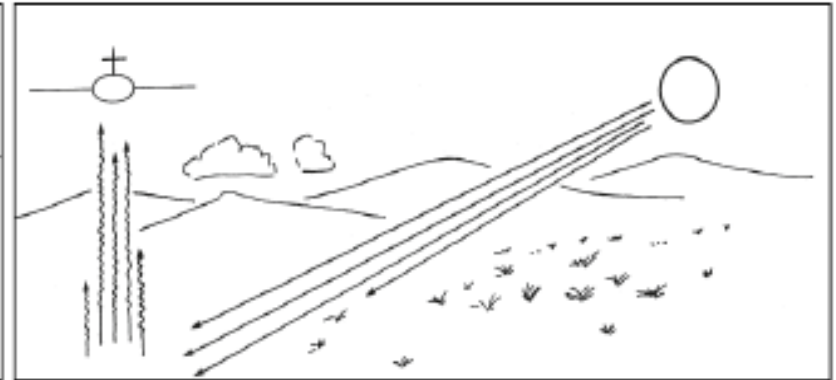

RS using emitted terrestrial radiation

## □ Active RS

### ■ Technological Assisted Radiation

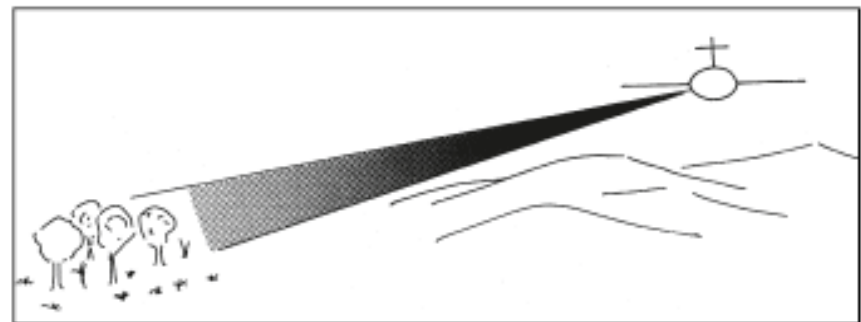

RS using sensor's transmitted radiation

## Passive vs. active systems

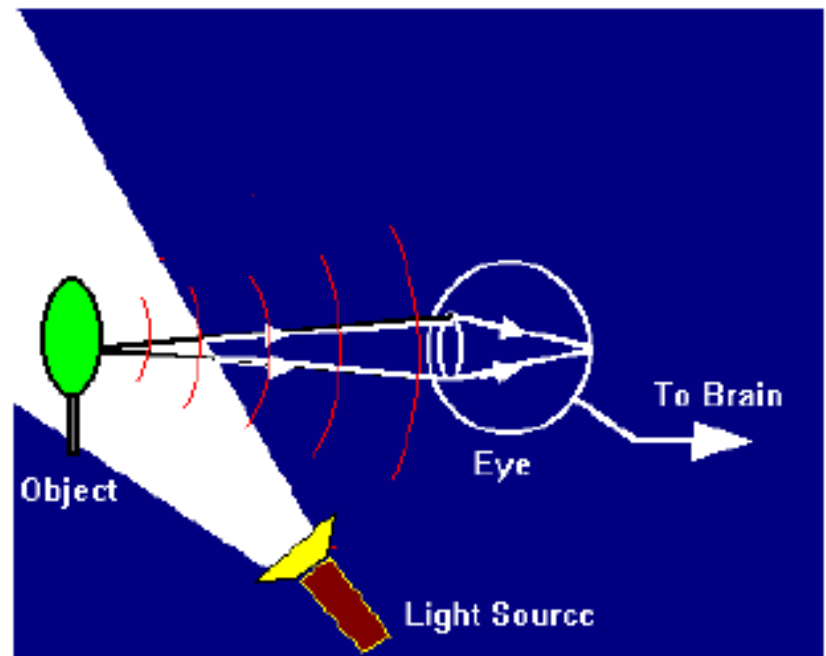
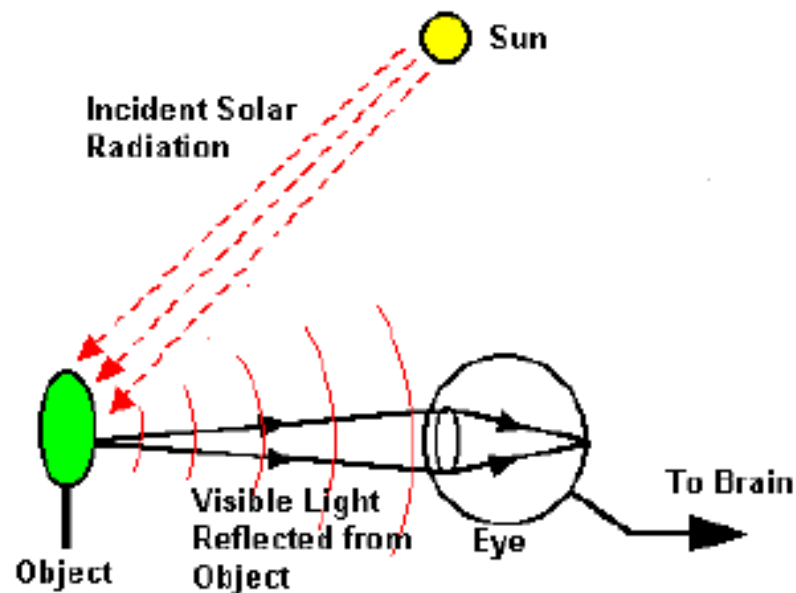

- Passive: measures naturally occurring radiation
- Active: Radar (radio), Lidar (visible light)

# Various Platforms of RS to record EM spectrum

22

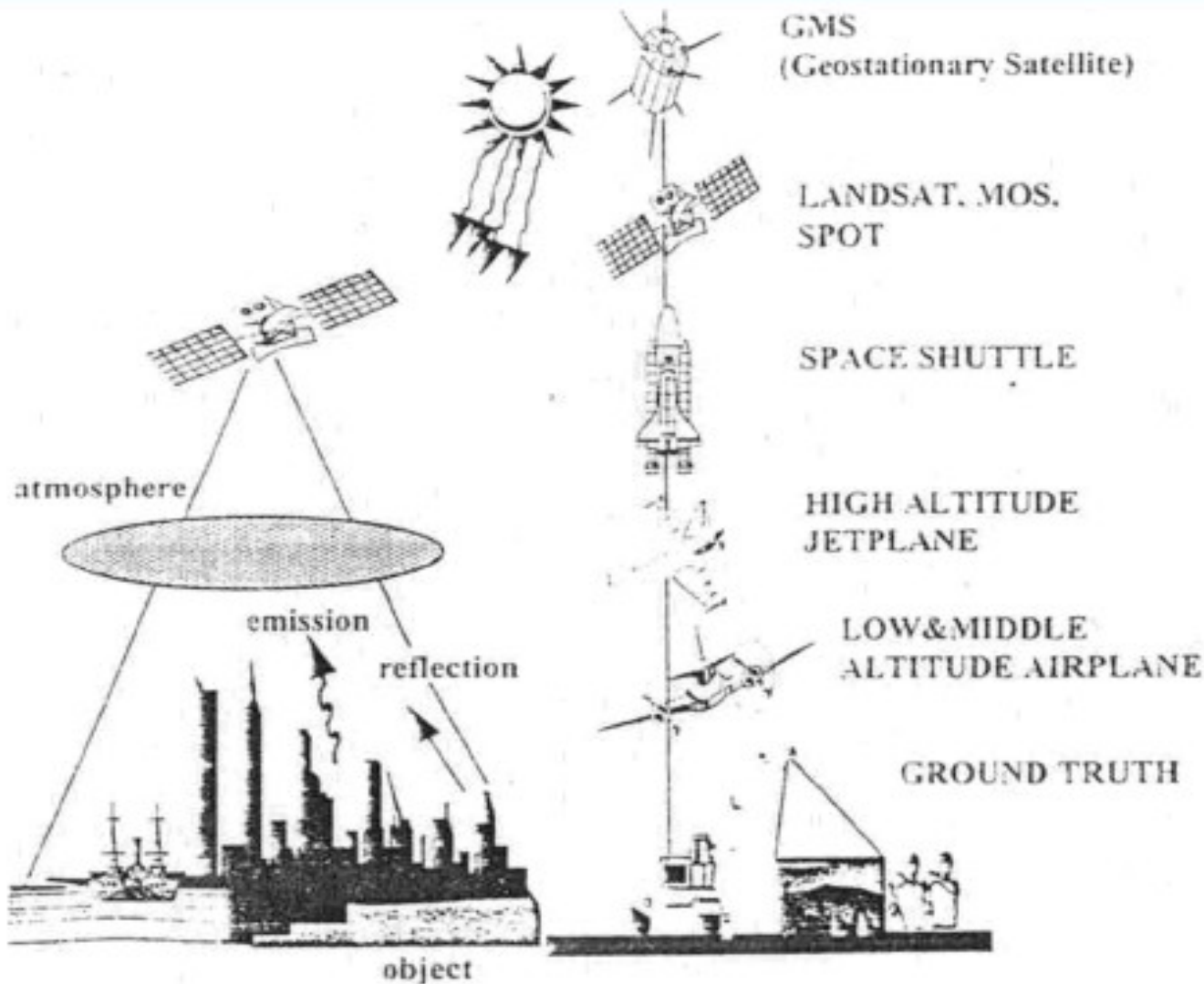

# NASA Global Hawk Unmanned Aerial Vehicle (UAV)



# RS and GIS of Earth Resources

24

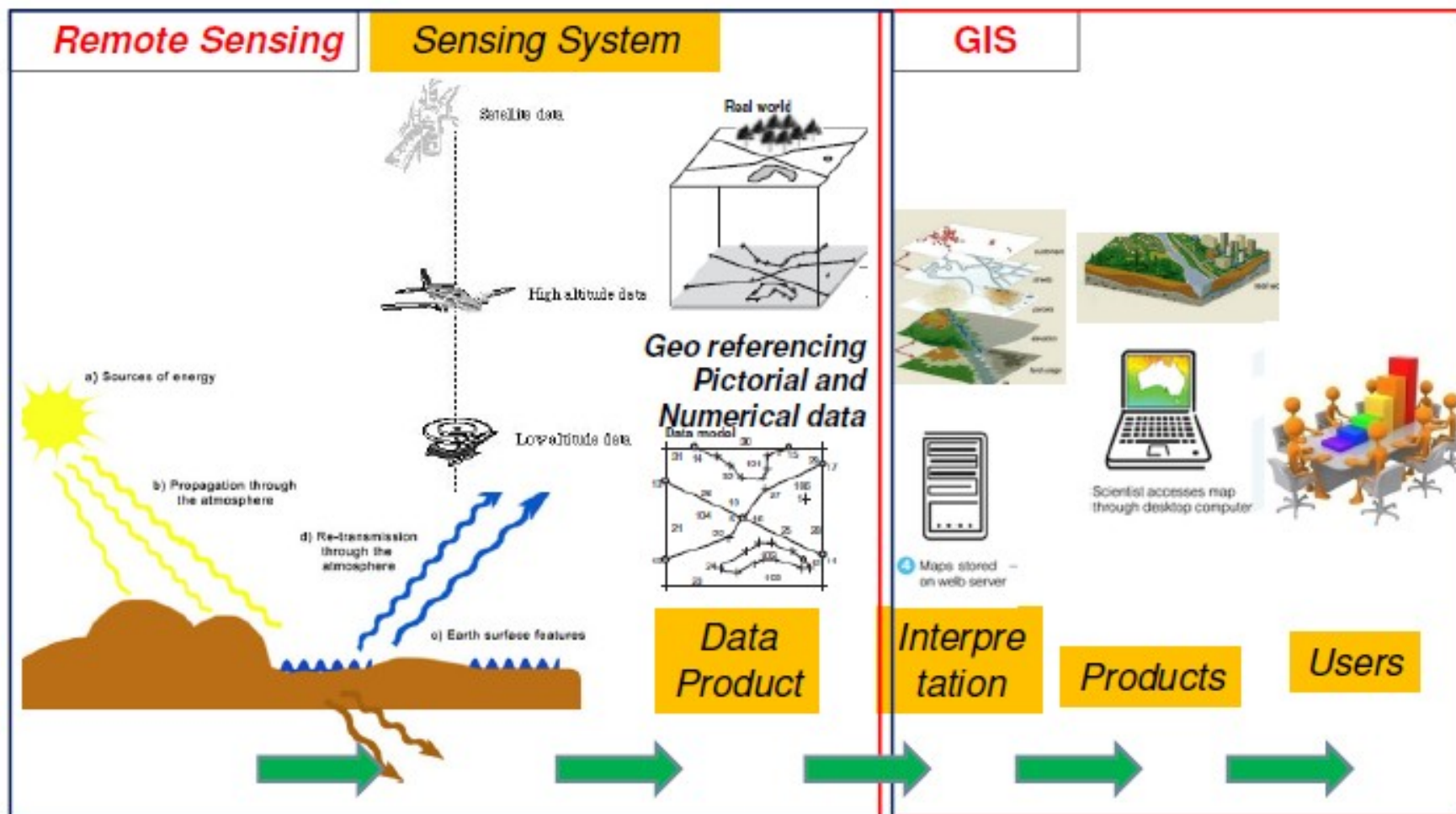

Electromagnetic remote sensing of earth and its processing

# Global Positioning System (GPS)

1. Define GPS. Why GPS is useful for GIS?
2. How GPS works?
3. What are the components of GPS? Describe with their functions.
4. What are the different errors in GPS? How they can be corrected?
5. What is differential GPS? Why is it necessary?

# Remote Sensing

6. What is remote sensing? How it differ from GPS?
7. Differentiate between active and passive sensor? How radar system works? Explain.
8. What are the different steps in remote sensing? Describe with illustrations.
9. Describe Electronic Magnetic Spectrum (EM) with illustrations.
10. What is atmospheric windows? Why is it important to develop sensors for RS?
11. What are the various platforms of RS to record EM spectrum? Describe briefly.

# Cameras and Aerial Photography

- Cameras and their use for aerial photography are the simplest and oldest of sensors used for remote sensing of the Earth's surface
- Cameras are **framing systems** which acquire a near-instantaneous "snapshot" of an **area (A)**, of the surface.
- Camera systems are passive optical sensors that use a **lens (B)** to form an image at the focal plane (C), the plane at which an image is sharply defined.

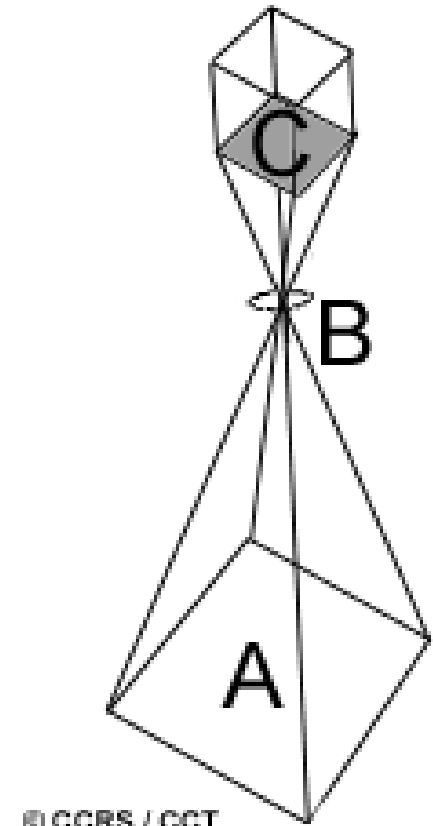



# Cameras and Aerial Photography

- **Photographic films** are sensitive to light from 0.3  $\mu\text{m}$  to 0.9  $\mu\text{m}$  in wavelength covering the ultraviolet (UV), visible, and near-infrared (NIR)
- **Panchromatic films** are sensitive to the UV and the visible portions of the spectrum. Panchromatic film produces black and white images and is the most common type of film used for aerial photography.
- Cameras can be used on a variety of **platforms** including ground-based stages, helicopters, aircraft, and spacecraft.
- Very detailed photographs taken from aircraft are useful for many applications
- Aerial photos can provide fine detail down to spatial resolutions of less than 50 cm.

# Cameras and Aerial Photography

- **Digital cameras** record electromagnetic radiation electronically,
- Instead of using film, it uses a gridded array of silicon coated CCDs (charge-coupled devices) that individually respond to electromagnetic radiation.
- Energy reaching the surface of the CCDs causes the generation of an electronic charge which is proportional in magnitude to the "brightness" of the ground area. A digital number for each spectral band is assigned to each pixel based on the magnitude of the electronic charge.
- Quicker turn-around for acquisition and retrieval of data and allow greater control of the spectral resolution.
- Capable of collecting data with a spatial resolution of 0.3m and with a spectral resolution of 0.012 nm to

# **Digital Imaging**

Introduction;

Digital Image;

Sensor;

Imaging by Scanning Technique;

Hyper-spectral Imaging;

Imaging by Non-scanning Technique;

Thermal Remote Sensing;

Other Sensors

# Digital Imaging

# Microwave Remote Sensing

- Microwave remote sensing, using microwave radiation using wavelengths from about one meter to a few tens of centimeters enables observation in all weather conditions without any restriction by cloud or rain.
- Whereas shorter wavelengths (e.g., visible and infrared) provide information on the upper layers of vegetation, the longer wavelengths of microwave and RF signals penetrate deeper into the canopy and substructure providing additional information
- So, this is an advantage that is not possible with the visible and/or infrared remote sensing.

- **Microwave region** from about 1 mm to 1 m and covers the longest wavelengths used for remote sensing
  - Ka, K, and Ku bands: very short wavelengths used in early airborne radar systems but uncommon today.
  - X-band: used extensively on airborne systems for military reconnaissance and terrain mapping
  - C-band: common on many airborne research systems (CCRS Convair-580 and NASA AirSAR) and spaceborne systems (including ERS-1 and 2 and RADARSAT).
  - S-band: used on board the Russian ALMAZ satellite.
  - L-band: used onboard American SEASAT and Japanese JERS-1 satellites

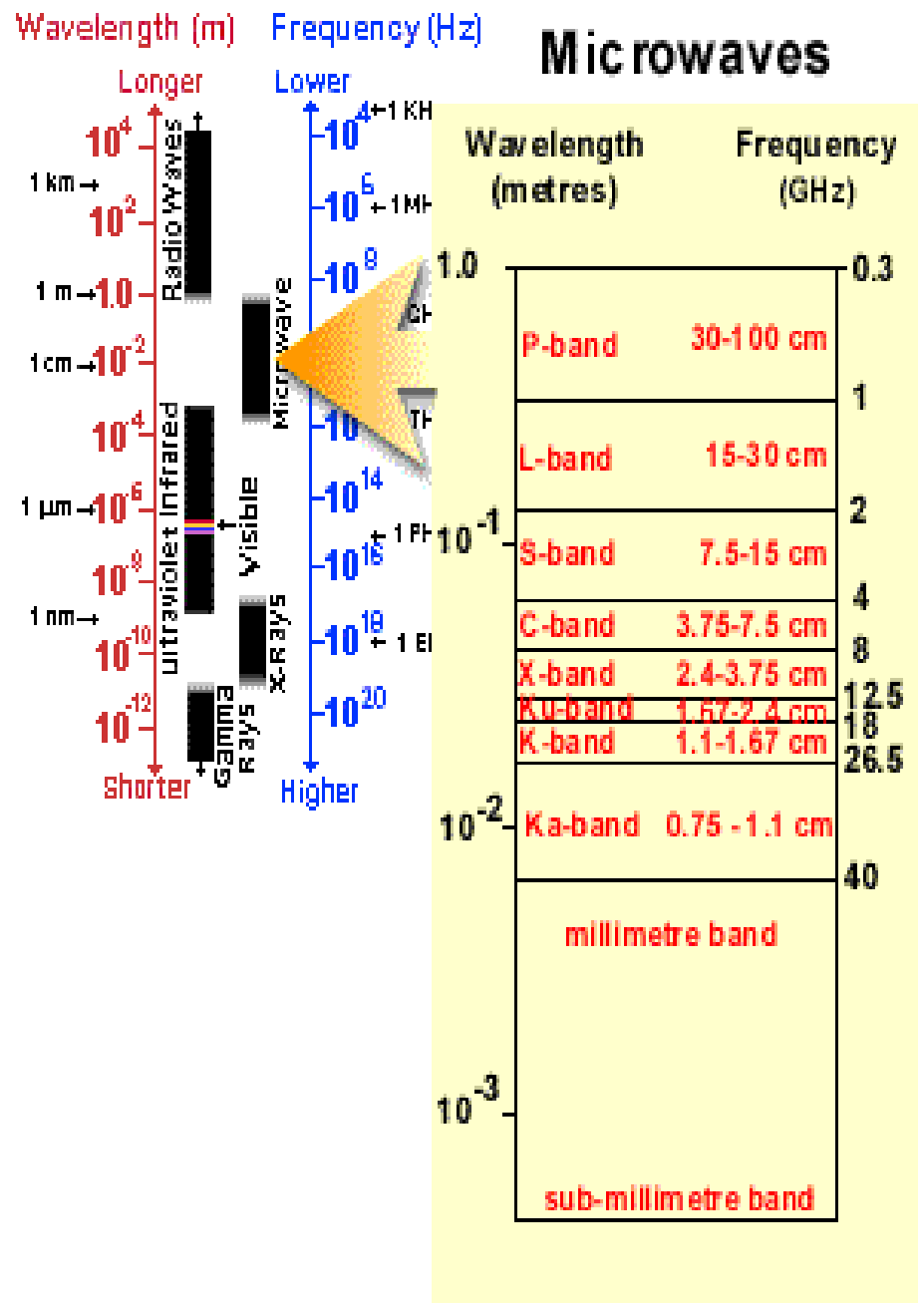

# Passive Microwave Remote Sensing

- A passive microwave sensor detects the naturally emitted microwave energy within its field of view.
- This emitted energy is related to the temperature and moisture properties of the emitting object or surface.

## The microwave energy recorded by a passive sensor

- emitted by the atmosphere (1), reflected from the surface (2), emitted from the surface (3), or transmitted from the subsurface (4)

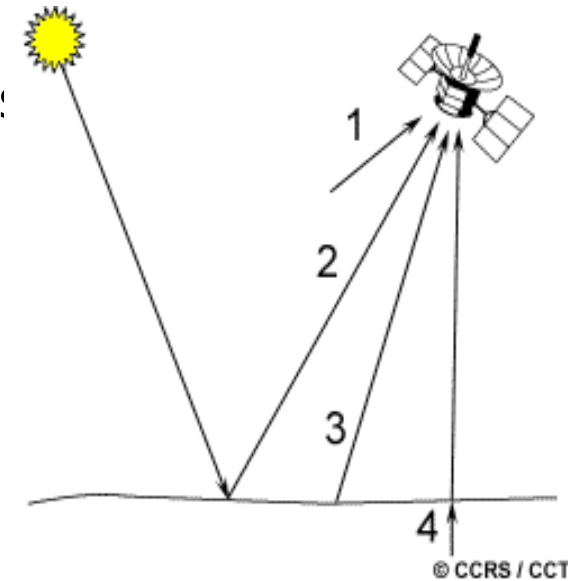

Applications of passive microwave remote sensing include meteorology, hydrology, and oceanography.

- Used for determine water and ozone content in the atmosphere
- measure soil moisture
- mapping sea ice, currents, and surface winds as well as detection of pollutants, such as oil slicks.

# Active Microwave Remote Sensing

- Active microwave sensors provide their own source of microwave radiation to illuminate the target.
- Operates in day and night, and largely immune to smoke, haze, fog, rain, snow,
- Active microwave sensors are generally divided into two distinct categories: **imaging and non-imaging**.
- The most common form of imaging active microwave sensors is RADAR (**RA**dio **D**etection **A**nd **R**anging)



# RADAR Imaging

- is the capability of the radiation to penetrate through cloud cover and most weather conditions.
- Because radar is an active sensor, it can also be used to image the surface at any time, day or night. These are the two primary advantages of radar: **all-weather and day or night** imaging.
- consists fundamentally of a transmitter, a receiver, an antenna, and an electronics system to process and record the data

# RADAR Imaging

- The transmitter generates successive short bursts (or **pulses** of microwave (A) at regular intervals which are focused by the antenna into a beam (B).
- The radar beam illuminates the surface obliquely at a right angle to the motion of the platform. The antenna receives a portion of the transmitted energy reflected (or **backscattered**) from various objects within the illuminated beam (C).

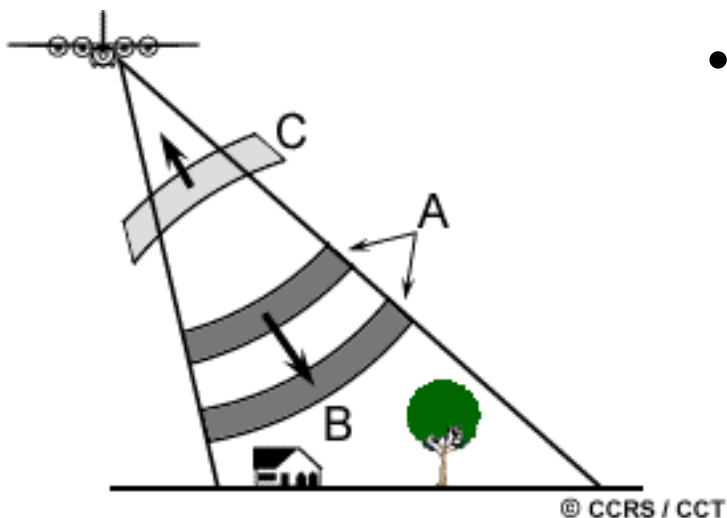

- By measuring the time delay between the transmission of a pulse and the reception of the backscattered "echo" from different targets, their distance from the radar and thus their location can be determined.

# Airborne Versus Space-borne

## Radars

### **Airborne Radars**

- Due to wider ranges of incidence angle (look angle), imaging geometry problems,
- flexible in their capability to collect data from different look angles and look directions. Additionally, an airborne radar is able to collect data anywhere and at any time (as long as weather and flying conditions are acceptable!).
- As with any aircraft, an airborne radar will be susceptible to variations in velocity and other motions of the aircraft as well as to environmental (weather) conditions.

### **Space-borne Radars**

- Avoid imaging geometry problems since they operate at altitudes up to one hundred times higher than airborne radars.
- A space-borne radar does not have this degree of flexibility, as its viewing geometry and data acquisition schedule is controlled by the pattern of its orbit. However, satellite radars do have the advantage of being able to collect imagery more quickly over a larger area than an airborne radar, and provide consistent viewing geometry.
- Space-borne radars are not affected by motion of this type. Indeed, the geometry of their orbits is usually very stable and their positions can be accurately calculated.

# Airborne Versus Space-borne Radars

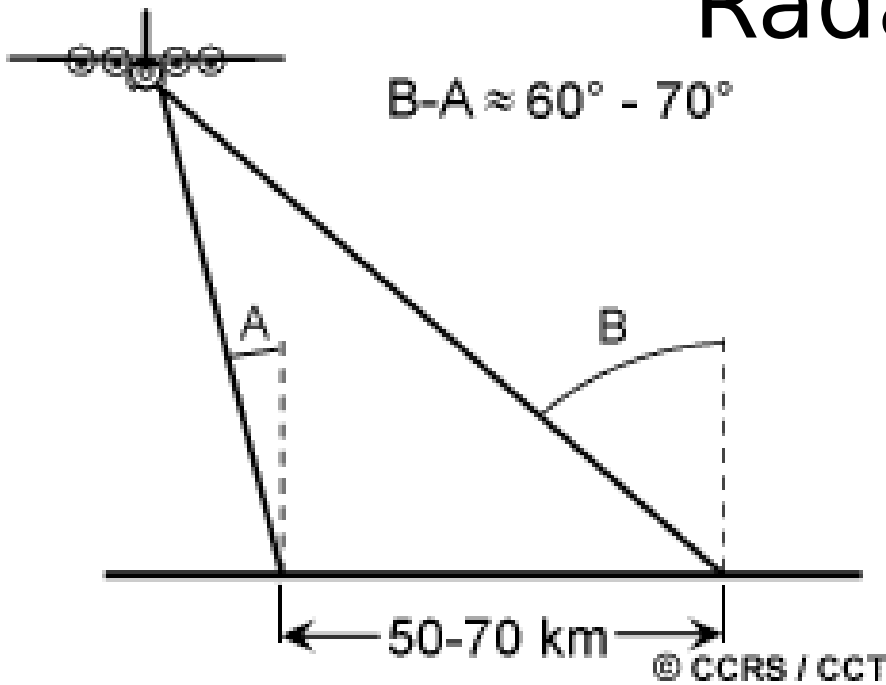

In airborne radar, wide range of incidence angles, perhaps as much as 60 or 70 degrees, in order to achieve relatively wide swaths (let's say 50 to 70 km)

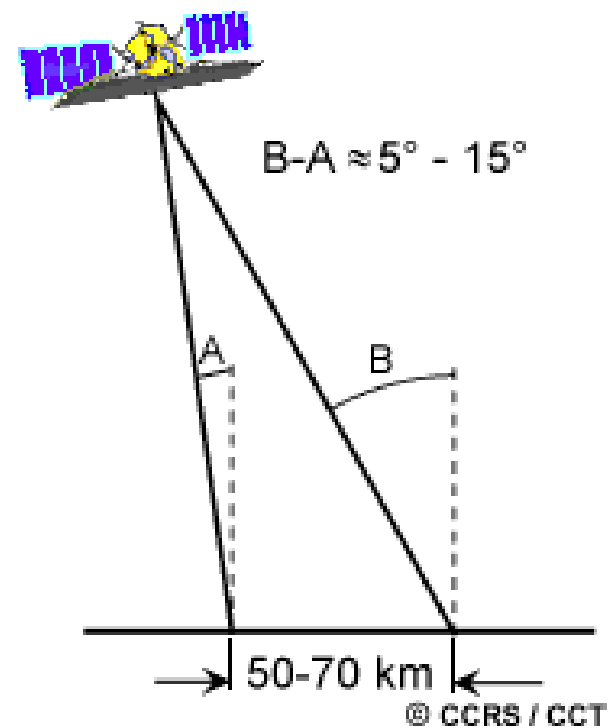

At altitudes of several hundred kilometres, space-borne radars can image comparable swath widths, but over a much narrower range of incidence angles, typically ranging from five to 15 degrees.

# Visual Image Interpretation

- Interpretation and analysis of remote sensing imagery involves the identification and/or measurement of various targets in an image in order to extract useful information about them.
- Targets in remote sensing images may be any feature or object which can be observed in an image, and have the following characteristics:
  - Targets may be a point, line, or area feature. This means that they can have any form, from a bus in a parking lot or plane on a runway, to a bridge or roadway, to a large expanse of water or a field.
  - The target must be distinguishable; it must contrast with other features around it in the image.
- Much interpretation and identification of targets in remote sensing imagery is performed manually or visually, i.e. by a human interpreter
- When remote sensing data are available in digital

# Visual Image Interpretation

## Manual interpretation

- Manual interpretation and analysis dates back to the early beginnings of remote sensing for air photo interpretation.
- manual interpretation requires little, if any, specialized equipment
- Manual interpretation is often limited to analyzing only a single channel of data or a single image at a time due to the difficulty in performing visual interpretation with multiple images
- Manual interpretation is a subjective process, meaning that the results will vary with different interpreters

## Digital processing

- Digital processing and analysis is more recent with the advent of digital recording of remote sensing data and the development of computers.
- digital analysis requires specialized, and often expensive, equipment
- digital analysis is useful for simultaneous analysis of many spectral bands and can process large data sets much faster than a human interpreter
- Digital analysis is based on the manipulation of digital numbers in a computer and is thus more objective, generally resulting in more consistent result

# Elements of Visual Interpretation

- Identifying targets in remotely sensed images based on following visual elements allows us to further interpret and analyze
  - **tone,**
  - **shape,**
  - **size,**
  - **pattern,**
  - **texture,**
  - **shadow, and**
  - **association**

# Elements of Visual Interpretation

- **Tone** refers to the relative brightness or colour of objects in an image
- Generally, tone is the fundamental element for distinguishing between different targets or features.
- Variations in tone also allows the elements of shape, texture, and pattern of objects to be distinguished.
- **Shape** refers to the general form, structure, or outline of individual objects.
- Shape can be a very distinctive clue for interpretation. Straight edge shapes typically represent urban or agricultural (field) targets, while natural features, such as forest edges, are generally more irregular in shape, except where man has created a road or clear cuts.





# Elements of Visual

## Size of objects in an image is a function of scale. It is important to assess the size of a target relative to other objects in a scene, as well as the absolute size, to aid in the interpretation of that target.

Size of objects in an image is a function of scale. It is important to assess the size of a target relative to other objects in a scene, as well as the absolute size, to aid in the interpretation of that target.



A quick approximation of target size can direct interpretation to an appropriate result more quickly..

- **Pattern** refers to the spatial arrangement of visibly discernible objects.
- Typically an orderly repetition of similar tones and textures will produce a distinctive and ultimately recognizable pattern. Orchards with evenly spaced trees, and urban streets with regularly spaced houses

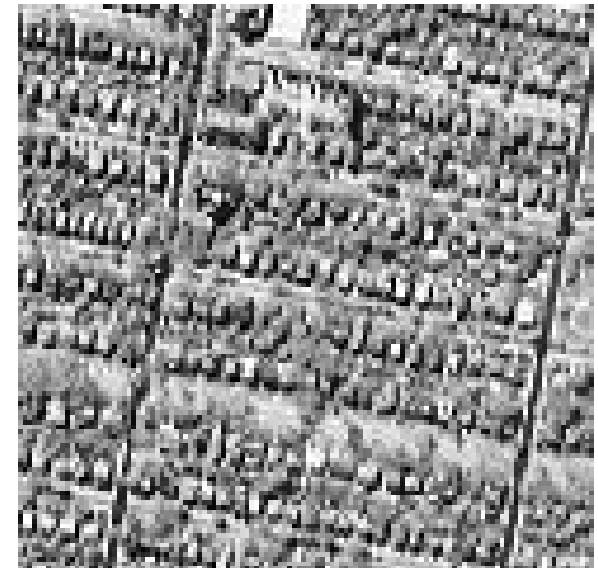

# Elements of Visual Interpretation

- **Texture** refers to the arrangement and frequency of tonal variation in particular areas of an image.
- Rough textures would consist of a mottled tone where the grey levels change abruptly in a small area, whereas smooth textures would have very little tonal variation.
- Smooth textures are most often the result of uniform, even surfaces, such as fields, asphalt, or grasslands.
- A target with a rough surface and irregular structure, such as a forest canopy, results in a rough textured appearance.
- Texture is one of the most



# Elements of Visual Interpretation

## Shadow

- **Shadow** is also helpful in interpretation as it may provide an idea of the profile and relative height of a target or targets which may make identification easier. However, shadows can also reduce or eliminate interpretation in their area of influence, since targets within shadows are much less (or not at all) discernible from their surroundings. Shadow is also useful for enhancing or identifying topography and landforms, particularly in radar imagery.



## Association

- **Association** takes into account the relationship between other recognizable objects or features in proximity to the target of interest. The identification of features that one would expect to associate with other features may provide information to facilitate identification. In the example given above, commercial properties may be associated with proximity to major transportation routes, whereas residential areas would be associated with schools, playgrounds, and sports fields. In our example, a lake is associated with boats, a marina, and adjacent recreational land.



# Digital Image Processing

- Digital image processing may involve numerous procedures including formatting and correcting of the data, digital enhancement to facilitate better visual interpretation, or even automated classification of targets and features entirely by computer.
- most of the common image processing functions available in image analysis systems can be categorized into the following four categories:
  - Preprocessing
  - Image Enhancement
  - Image Transformation
  - Image Classification and Analysis

# Digital Image Processing

- **Preprocessing** functions involve those operations that are normally required prior to the main data analysis and extraction of information, and are generally grouped **as radiometric or geometric corrections**
- Radiometric corrections include correcting the data for sensor irregularities and unwanted sensor or atmospheric noise, and converting the data so they accurately represent the reflected or emitted radiation measured by the sensor.
- Geometric corrections include correcting for geometric distortions due to sensor-Earth geometry variations, and conversion of the data to real world coordinates (e.g. latitude and longitude) on the Earth's surface.

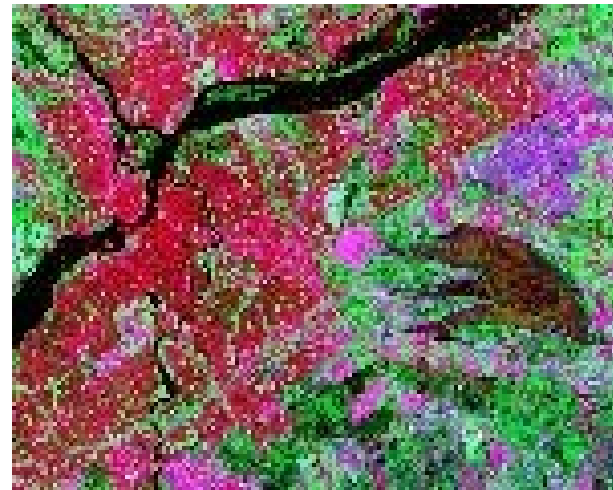
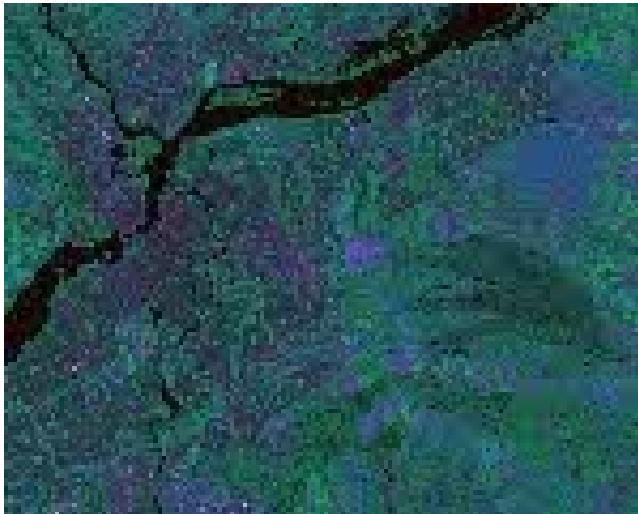

# Digital Image Processing

## Image enhancement

- is solely to **improve the appearance of the imagery** to assist in visual interpretation and analysis.
- Examples of enhancement functions include contrast stretching to increase the tonal distinction between various features in a scene, and **spatial filtering** to enhance (or suppress) specific spatial patterns in an image.

# Digital Image Processing

## Image transformations

- are operations similar in concept to those for image enhancement. However, unlike image enhancement operations which are normally applied only to a single channel of data at a time, image transformations usually involve combined processing of data from multiple spectral bands.
- Arithmetic operations (i.e. subtraction, addition, multiplication, division) are performed to combine and transform the original bands into "new" images which better display or highlight certain features in the scene.
- We will look at some of these operations including various methods of **spectral or band** ratioing, and a procedure called **principal components analysis** which is used to more efficiently represent the information in multichannel imagery

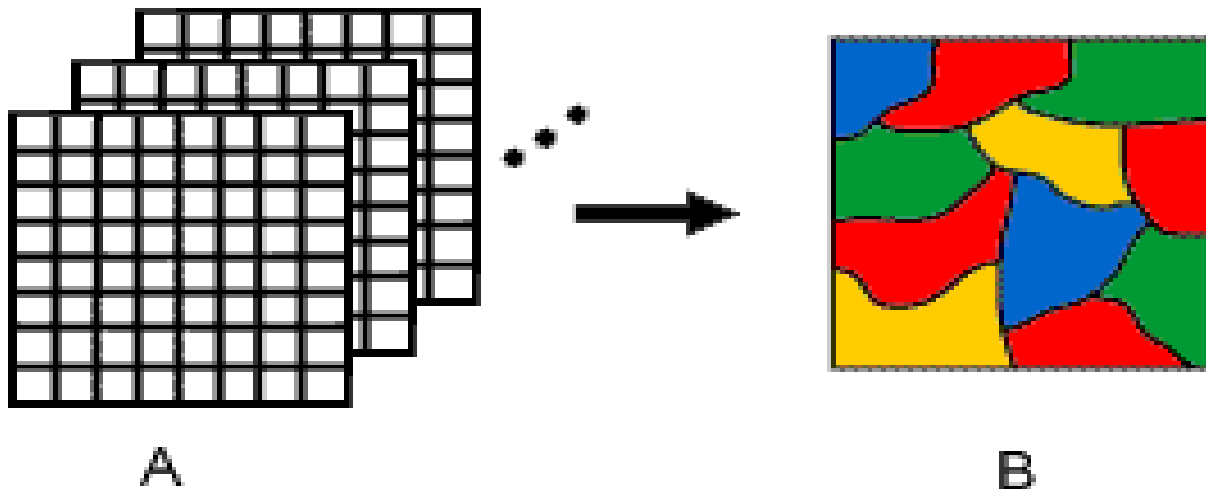

# Digital Image Processing

## Image classification and analysis

- are used to digitally identify and classify pixels in the data.
- **Classification** is usually performed on multi-channel data sets (A) and this process assigns each pixel in an image to a particular class or theme (B) based on statistical characteristics of the pixel brightness values.
- There are a variety of approaches taken to perform digital classification.
- We will briefly describe the two generic approaches which are used most often, namely **supervised** and **unsupervised** classification.



# Data Integration, Analysis, and Presentation

## RS and GIS of Earth Resources

24

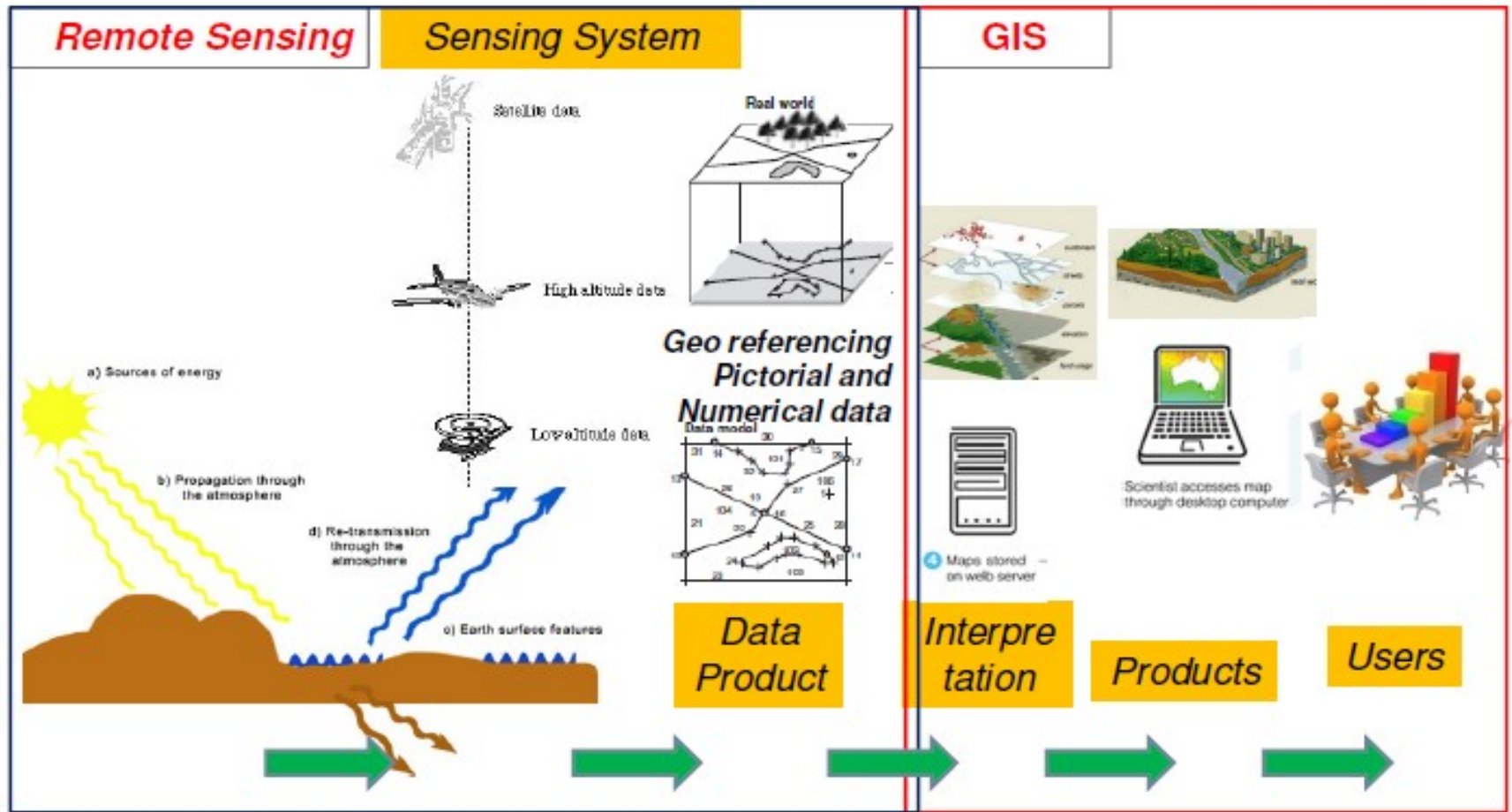

Electromagnetic remote sensing of earth and its processing

# Introduction; **Photogrammetry**

Development and Classification;

Photogrammetric Process;

Acquisition of Imagery and its Support Data;

Orientation and Triangulation;

Stereo Model Compilation;

Stereoscopic 3D Viewing;

Stereoscopic Measurement;

DTM/DEM Generation;

Counter Map Generation;

Orthorectification;

3D Feature Extraction and 3D Scene Modeling;

Photogrammetry and LiDAR;

Radargrammetry and Radar

Interferometry;

Limitations

# Photogrammetry

**Photogrammetry** is the science of obtaining reliable information about the properties of surfaces and objects without physical contact with the objects, and of measuring and interpreting this information.

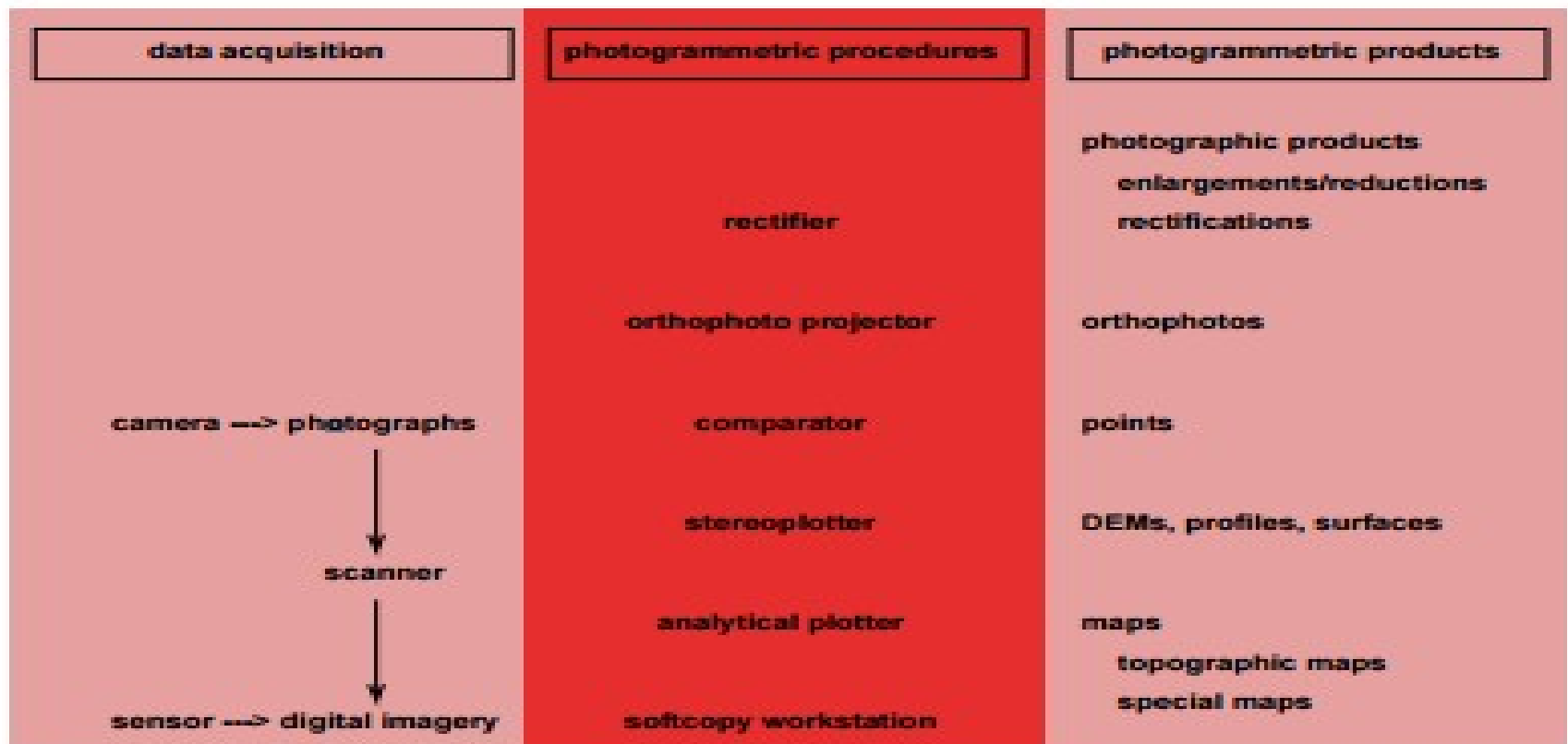

# Photogrammetric Products and Procedures

- Photogrammetric products fall into three categories: photographic products, computational results, and maps.
  - Photographic products are derivatives of single photographs or composites of overlapping photographs
  - *Aerial triangulation is a very successful application of photogrammetry and delivers 3-D positions of points, measured on photographs, in a ground control coordinate system,*
  - most popular form for representing portions of the earth's surface is the DEM (Digital Elevation Model)
  - Maps are the most prominent product of photogrammetry: Planimetric maps, topographic maps, Thematic maps

# Photogrammetric Products and Procedures

- Photogrammetric Input
  - aerial photograph
- Projection system-
- amount of data (~ 0.5 GB of 9 inches size of photo)
- Implicit information - clearly expressed (data labeled, feature has attribute information...)
- Output - map
- Projection system - Orthogonal
- Less amount of data
- Explicit information - not directly expressed (pixel have no attribute .....)

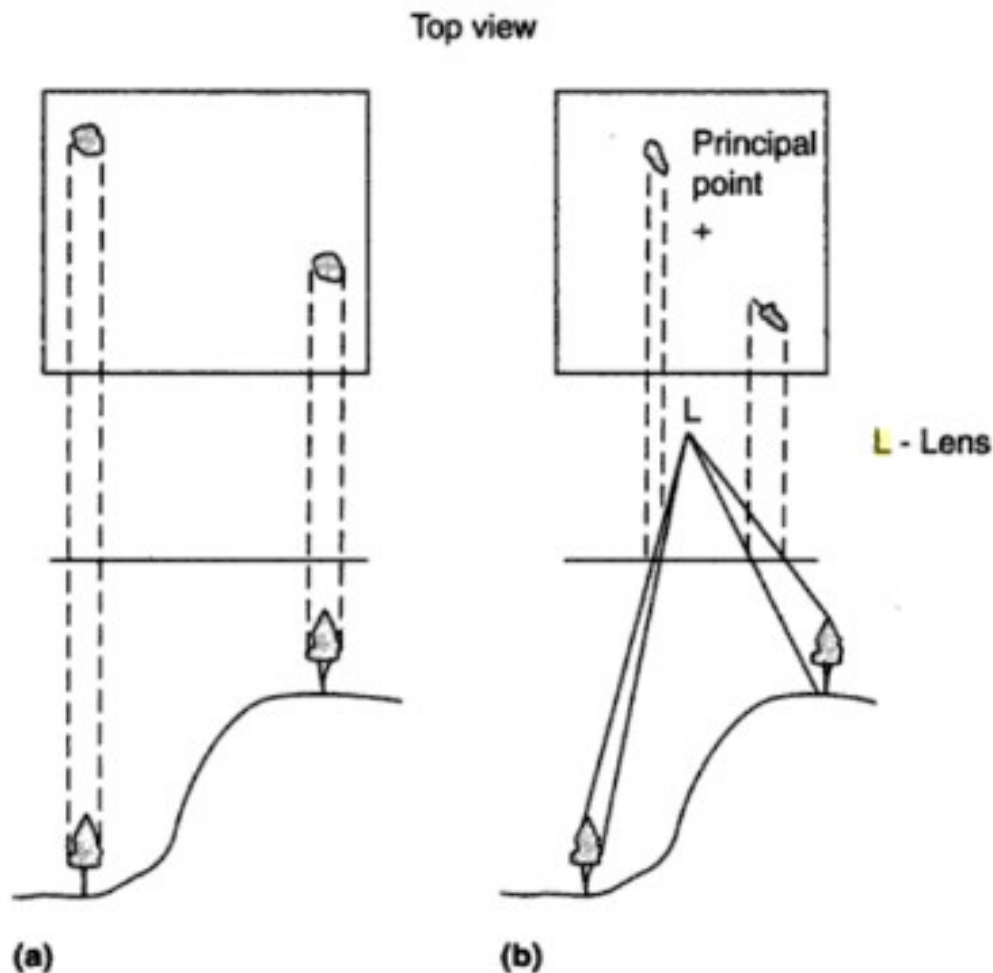

**Fig. 6.11** The geometrical differences in a map. (a) (orthographic projection) and a vertical aerial photograph; (b) (central projection). In the map (a), we have a top view of the object in its true relative horizontal position. (Reprinted from 'Remote Sensing and Image Interpretation', 1<sup>st</sup> Edn., Lillesand & Kieffer, 1979, with permission of John Wiley & Sons, Inc)

# Historical Development

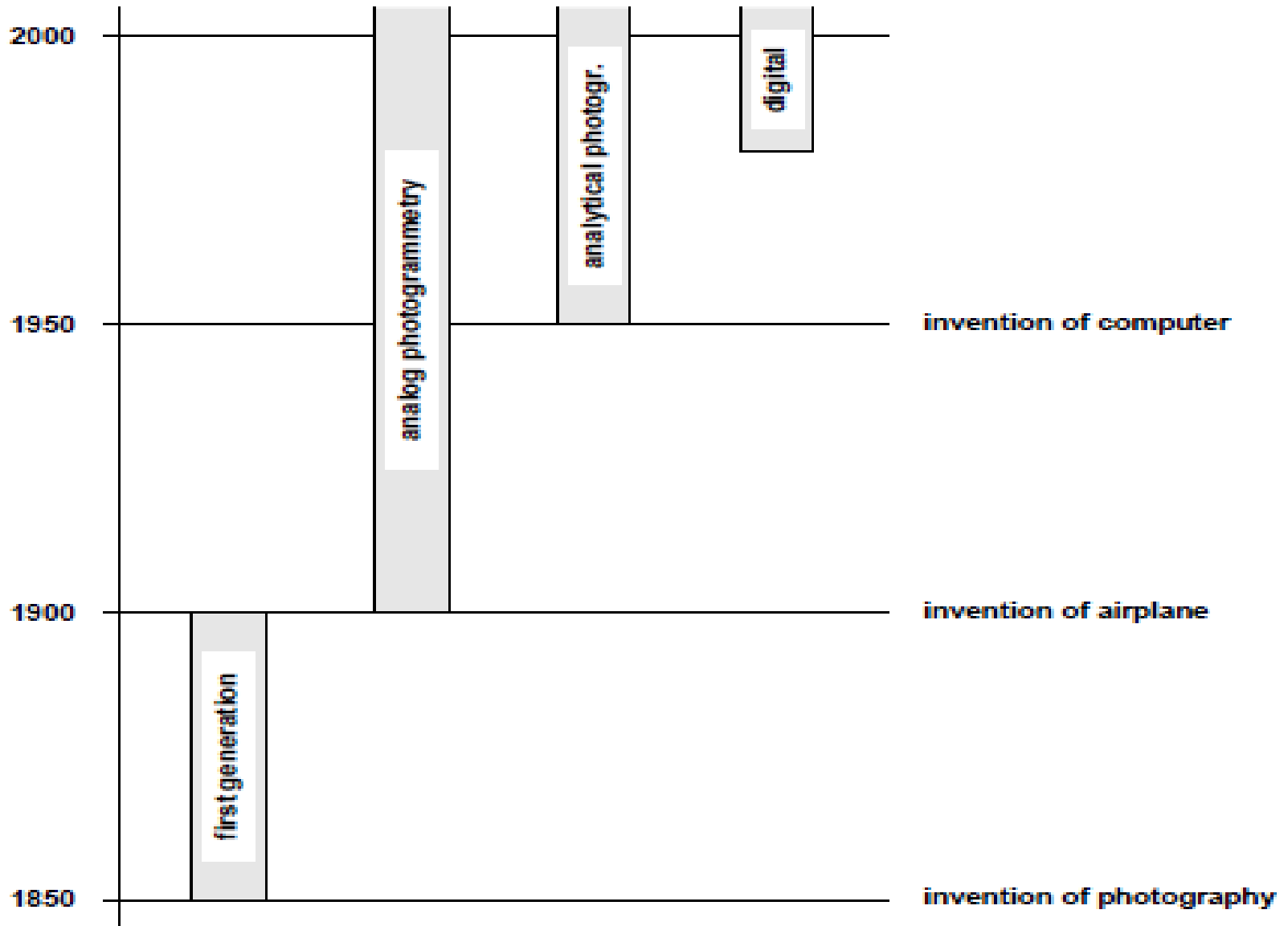

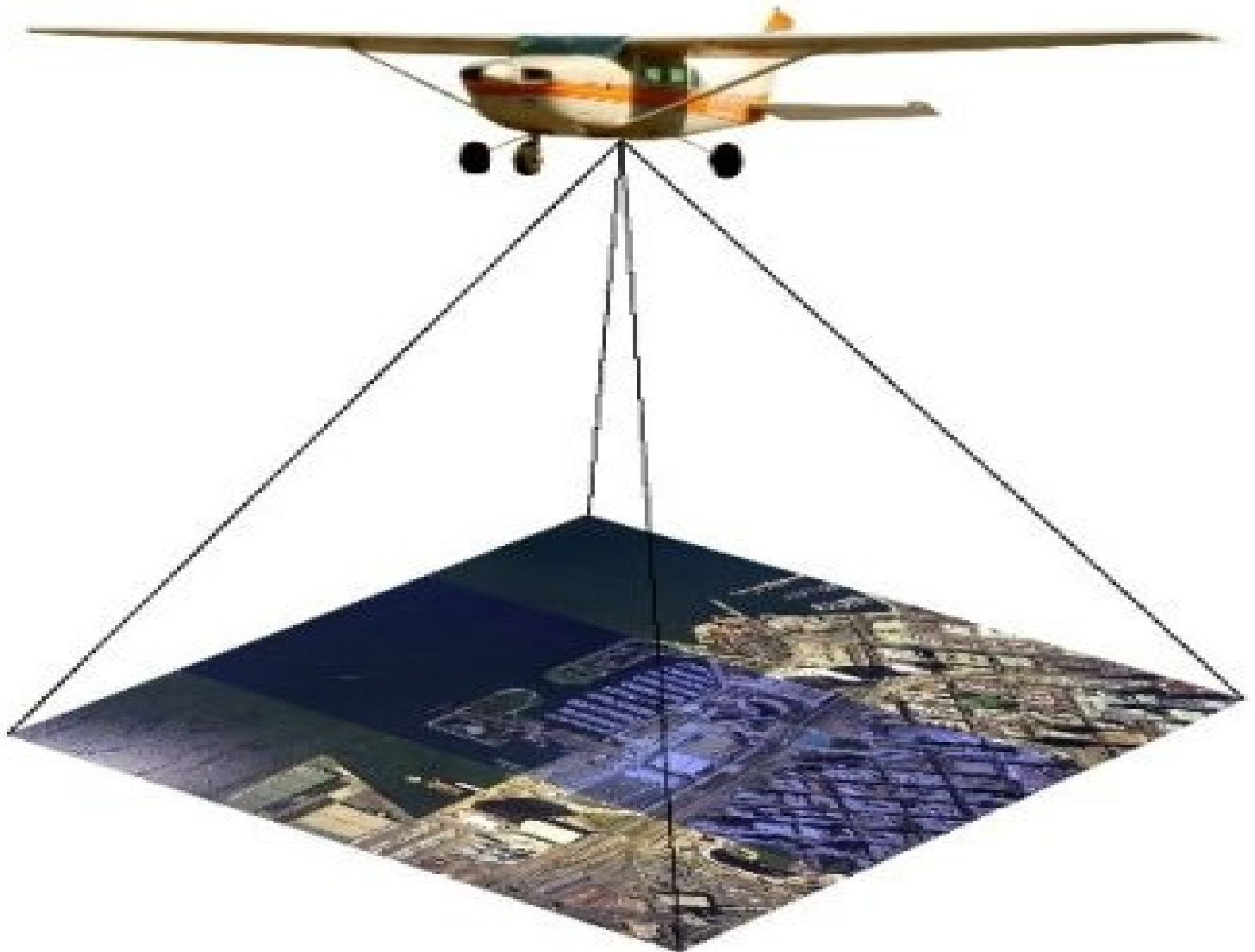



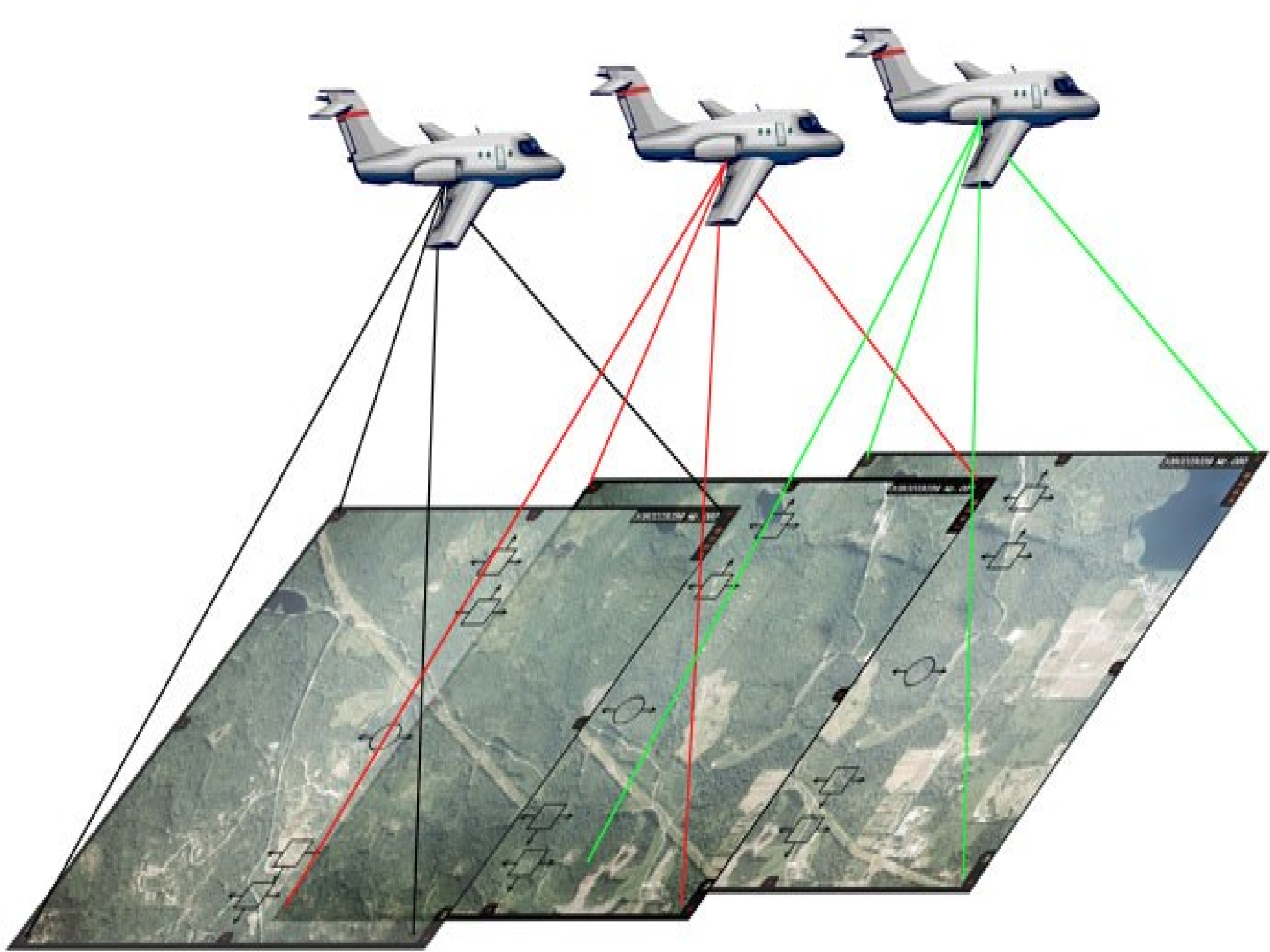

# Scale of Vertical Photograph

- Ratio of distance in photo to the same distance on ground
- Photographs are not map..
- Orthophoto
- Scale of at any points,
  - $s = f/(H-h)$
  - $S_{avg} = f/(H-h_{avg})$
- If the  $f$ ,  $H$ ,  $h$  are not available, but a map is available,
  - **Photo scale = Photo distance/map distance x (map scale)**

# Scale of Vertical Photograph

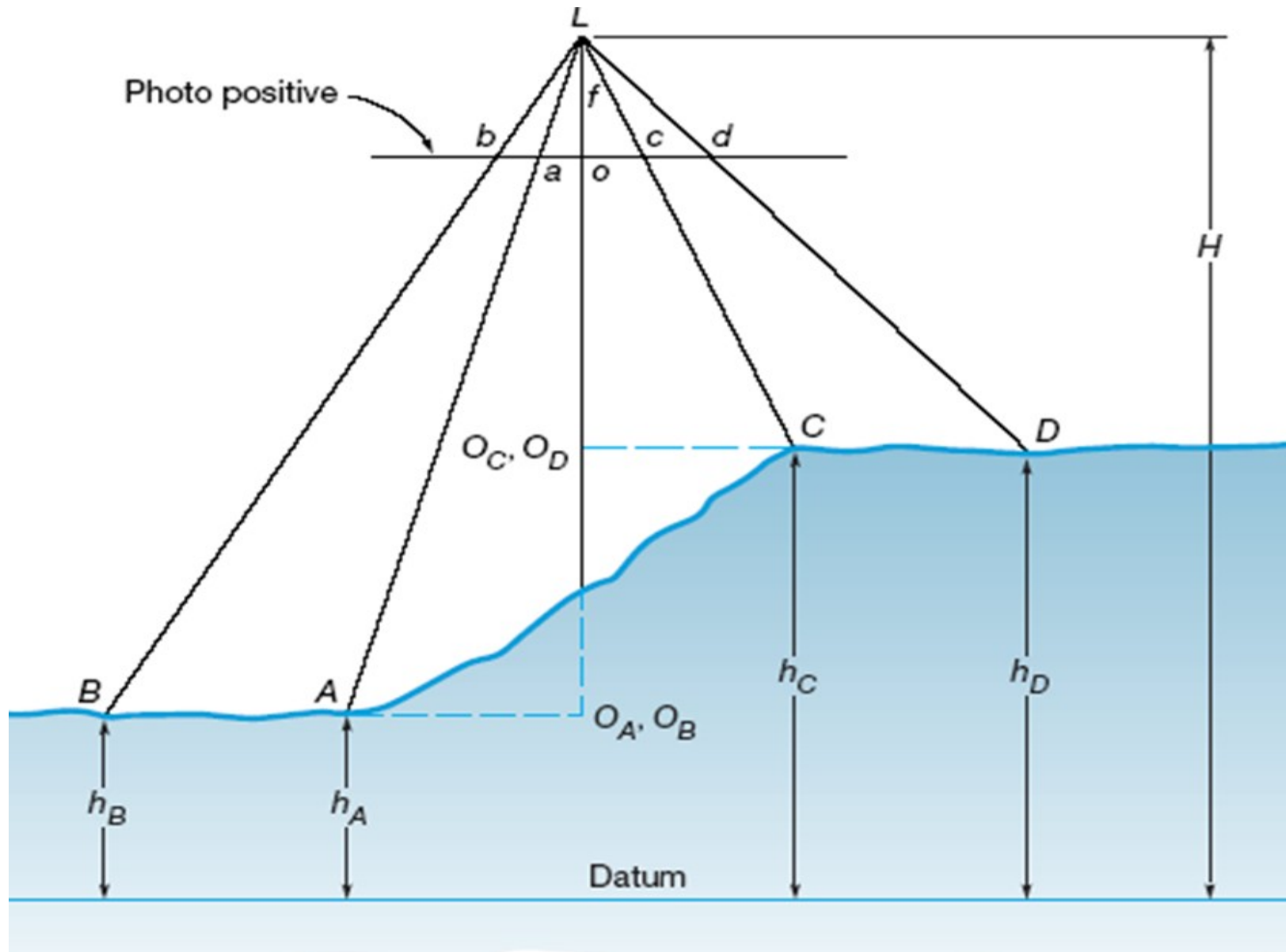

# Relief displacement

The effect of relief does not only cause a change in the scale but can also be considered as a component of image displacement. Fig. 4.5 illustrates this concept. Suppose point  $T$  is on top of a building and point  $B$  at the bottom. On a map, both points have identical  $X, Y$  coordinates; however, on the photograph they are imaged at different positions, namely in  $T'$  and  $B'$ . The distance  $d$  between the two photo points is called *relief displacement* because it is caused by the elevation difference  $\Delta h$  between  $T$  and  $B$ .

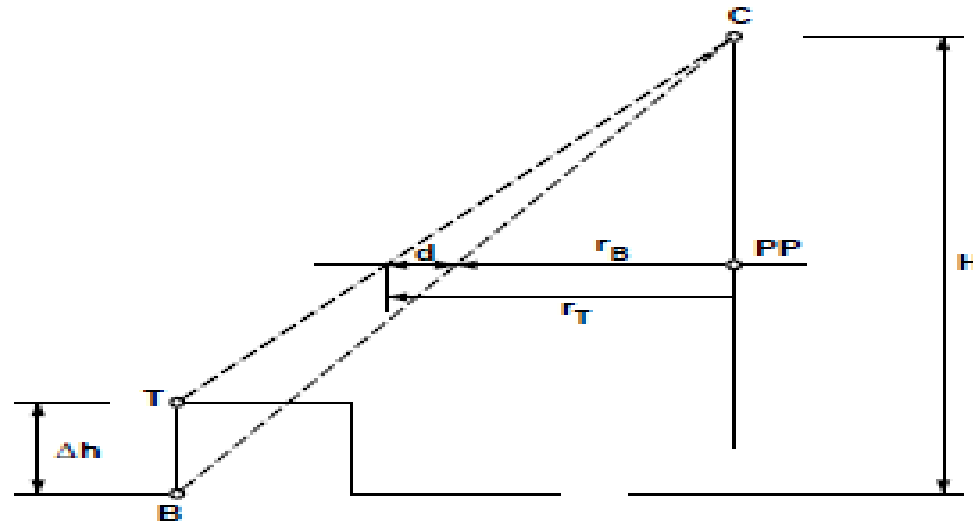

Figure 4.5: Relief displacement.

The magnitude of relief displacement for a true vertical photograph can be determined by the following equation

$$d = \frac{r \Delta h}{H} = \frac{r' \Delta h}{H - \Delta h} \quad (4.5)$$

where  $r = \sqrt{x_T^2 + y_T^2}$ ,  $r' = \sqrt{x_B^2 + y_B^2}$ , and  $\Delta h$  the elevation difference of two points on a vertical. Eq. 4.5 can be used to determine the elevation  $\Delta h$  of a vertical object

$$h = \frac{d H}{r} \quad (4.6)$$

# Orientation and Triangulation

# Stereo Model Compilation, Stereoscopic 3D Viewing and Stereoscopic Measurement